

DECswitch 900ET

Installation and Configuration

Part Number: EK-DETER-IN. A01

March 1996

This book describes how to install and configure the DECswitch 900ET module.

Revision/Update Information: This is a new document.

Digital Equipment Corporation makes no representations that the use of its products in the manner described in this publication will not infringe on existing or future patent rights, nor do the descriptions contained in this publication imply the granting of licenses to make, use, or sell equipment or software in accordance with the description.

Possession, use, or copying of the software described in this publication is authorized only pursuant to a valid written license from Digital or an authorized sublicensor.

© Digital Equipment Corporation 1996. All rights reserved.

The following are trademarks of Digital Equipment Corporation:

DEC, DECswitch, DECconnect, DEChub, DECnet, Digital, clearVISN, MultiSwitch, ThinWire, and the DIGITAL logo.

AppleTalk is a registered trademark of Apple Computer, Inc.

Novell and IPX are registered trademarks of Novell, Inc.

FCC NOTICE - Class A Computing Device:

This equipment generates, uses, and may emit radio frequency energy. The equipment has been type tested and found to comply with the limits for a Class A computing device pursuant to Subpart J of Part 15 of FCC Rules, which are designed to provide reasonable protection against such radio frequency interference when operated in a commercial environment. Operation of this equipment in a residential area may cause interference; in which case, measures taken to correct the interference are at the user's expense.

VCCI NOTICE - Class 1 Computing Device:

This equipment is in the 1st Class category (information equipment to be used in commercial and/or industrial areas) and conforms to the standards set by the Voluntary Control Council for Interference by Data Processing Equipment and Electronic Office Machines aimed at preventing radio interference in commercial and/or industrial areas. Consequently, when used in a residential area or in an adjacent area thereto, radio interference may be caused to radios and TV receivers. Read the instructions for correct handling.

CE NOTICE - Class A Computing Device:

Warning!

This is a Class A product. In a domestic environment this product may cause radio interference, in which case the user may be required to take adequate measures.

Achtung!

Dieses ist ein Gerät der Funkstörgrenzwertklasse A. In Wohnbereichen können bei Betrieb dieses Gerätes Rundfunkstörungen auftreten, in welchen Fällen der Benutzer für entsprechende Gegenmaßnahmen verantwortlich ist.

Attention!

Ceci est un produit de Classe A. Dans un environnement domestique, ce produit risque de créer des interférences radioélectriques, il appartient alors à l'utilisateur de prendre les mesures spécifiques appropriées.

CONTENTS

Preface

- Overviewvii
- Organization.....viii
- Associated Documents.....ix
- Conventions and Terms.....xi
- Correspondence.....xii
- How to Order Additional Documentation.....xiii

Safety

- Overviewxv

1 Product Introduction

- Overview 1-1
- What is the DECswitch 900ET? 1-2
- Features 1-3
- Front Panel Features..... 1-6
- Back Panel Features..... 1-9

2 Installing the Module

- Overview 2-1
- Installing the Module in a DEChub 900 2-2
- Task 1: Compare the Power Ratings 2-3
- Task 2: Seat the Module into the DEChub 900 2-4
- Task 3: Verify Initial LED Operation 2-5
- Task 4: Connect the Cables 2-6

3 Installing the Setup Port Cable

Overview	3-1
Signaling Standards	3-2
Setup Port Device Cabling	3-2
Connecting the Setup Port	3-3

4 Setting Up and Configuring the Module in a DEChub ONE

Overview	4-1
Accessing the Setup Port	4-2
Using Menus to Setup the Module	4-3
Go to Local Console	4-18
CONFIG Commands	4-21
Configuring Token-Ring Port Connection (0 or 1)	4-22
Configuring Ethernet Port 2 Connection	4-23
Configuring OBM	4-24

5 Configuring the Module in a DEChub 900

Overview	5-1
Accessing the Setup Port	5-2
DEChub 900 MultiSwitch Installation Menu	5-3
Using Menus to Setup the Module	5-5
Using Telnet to Configure Interfaces	5-17
Configuring Token-Ring Port Connection (0 or 1)	5-19
Configuring Ethernet Port 2 Connection	5-20
Configuring OBM	5-21

6 Removing the Module

Overview	6-1
Removing the Cables	6-2
Unseating the Module	6-3

A Problem Solving

Overview	A-1
LED Descriptions	A-2

Problem Solving Using LEDsA-3

B Connector and Pin Assignments

OverviewB-1
Connector AssignmentsB-2
Internal and External Crossover ConfigurationsB-6

C Product Specifications

OverviewC-1
Operating SpecificationsC-2
Acoustical SpecificationsC-5

Preface

Overview

About this Manual

This manual describes how to install the DECswitch 900ET in a DEChub 900 MultiSwitch. (How to install the DECswitch 900ET in the DEChub ONE docking station is described in the *DEChub ONE Installation* manual.) This manual also describes how to configure the DECswitch 900ET software to operate in either a DEChub 900 MultiSwitch or as a standalone module in a DEChub ONE docking station.

Intended Audience

This manual is intended for use by personnel who will install and configure the DECswitch 900ET module.

Organization

This manual is organized as follows:

Section	Description
1	Provides an overview of the DECswitch 900ET, describes its features, and lists front and back panel features.
2	Provides instructions for installing the module in a DEChub 900 MultiSwitch.
3	Provides instructions for installing the setup port cable.
4	Provides instructions for configuring the module in a DEChub ONE.
5	Provides instructions for configuring the module in a DEChub 900 MultiSwitch.
6	Provides instructions for removing the module from a DEChub 900 MultiSwitch.
A	Provides installation-specific troubleshooting information using the LEDs.
B	Provides connector and pin assignment information.
C	Provides product specifications.

Associated Documents

The following documents provide information relating to the module. To order any of these documents, refer to the section titled How to Order Additional Documentation.

Title and Order Number	Description
<i>clearVISN Overview and Concepts</i>	Provides an overview and concepts for clearVISN.
<i>clearVISN Configuration and Use</i>	Describes how to configure and use clearVISN applications.
<i>clearVISN Installation</i>	Describes how to install clearVISN applications.
<i>DEChub ONE Installation</i> EK-DEHU2-IN	Provides installation and operation guidelines for single-slot hub configuration, including rack-mount options and cabling.
<i>Bridging Configuration Guide</i> AA-QL29B-TE	Describes bridging methods, operational features of bridging, configuration methods and basic configurations, and monitoring of bridging software.
<i>DEChub 900 MultiSwitch Owner's Manual</i> EK-DH2MS-OM	Provides installation, use, security, and troubleshooting information for the DEChub 900 MultiSwitch.
<i>Event Logging System Messages Guide</i> AA-QL2AB-TE	Describes messages logged by the Event Logging System.
	(continued)
<i>Network Interface Operations Guide</i> AA-QL2BB-TE	Describes the configuring and monitoring of the network interfaces in the Bridge Router Software bridging router.

Title and Order Number	Description
<i>Distributed Routing Software Router Protocols Reference Guide</i> AA-QL2CB-TE	Provides detailed reference information about the micro-operating system structure and the protocols and interfaces that the bridging routers support.
Systems Network Architecture Guide AA-QU5SA-TE	Supports IBM's Systems Network Architecture (SNA) and Data Link Switching (DLSw).
<i>Distributed Routing Software Routing Protocols Users Guide</i> AA-QL2DB-TE	Explains how to configure and monitor the routing protocol software.
<i>System Software Guide</i> AA-QL2EB-TE	Describes the installation, configuration, and operation of the Bridge Router Software.

Conventions and Terms

Overview

This book uses the following conventions and terms:

Convention	Description
Bold Type	Indicates user input
Monospaced Type	Indicates system output
16.20.54.156	The format of an IP address is the standard 4-octet dotted decimal notation, where each octet of the address is represented as a decimal value, separated by a decimal point (.).
<i>Italics</i>	In examples, indicates user input.
[]	Contain default responses to the installation menu prompts.
<Return>	Indicates that you press the Return Key.
08-00-2B-A3-00-00	This format represents a Media Access Control (MAC) address in examples and figures.
SNMP	The Simple Network Management Protocol (SNMP) is an industry standard protocol for network management.
ThinWire Cable	This cable is an IEEE 10base2 Coaxial cable that carries Ethernet signals.
Ethernet	The Digital's term for its product's compatibility with the ISO 8802-3/ANSI/IEEE 802.3 standards and the Ethernet standards for Carrier Sense Multiple Access with Collision Detection (CSMA/CD) local area networks (LANs).

Correspondence

Documentation Comments

If you have comments or suggestions about this document, send them to the Network Products Business Organization.

Attn.: Documentation Project Manager
FAX: (508) 486-6093
E-MAIL: doc_quality@lkg.mts.dec.com

Online Services

To locate product specific information, refer to the following online services:

BBS To read the Bulletin Board System, set your modem to 8 bits, no parity, 1 stop bit and dial 508-486-5766 (U.S.)

WWW The Digital Equipment Corporation Network Products Business Home Page on the World Wide Web is at the following addresses:

North America: <http://www.networks.digital.com>

Europe: <http://www.networks.europe.digital.com>

Australia: <http://www.digital.com.au/networks>

How to Order Additional Documentation

To order additional documentation, use the following information:

To Order:	Contact:
By Telephone	Continental USA: 1-800-DIGITAL (1-800-344-4825) Canada: 1-800-267-6215 Alaska, New Hampshire, and Hawaii: 1-603-884-6660
Electronically (USA. only)	Dial 1-800-DEC-DEMO (For assistance, call 1-800-DIGITAL)
By Mail (USA and Puerto Rico)	DIGITAL EQUIPMENT CORPORATION P.O. Box CS2008 Nashua, New Hampshire 030601-1260 (Place prepaid orders from Puerto Rico with the local Digital subsidiary: 809-754-7575)
By Mail (Canada)	DIGITAL EQUIPMENT CORPORATION LTD. 940 Belfast Road Ottawa, Ontario, Canada K1G 4C2 Attn: A&SG Business Manager
Internationally	DIGITAL EQUIPMENT CORPORATION A&SG Business Manager c/o local Digital subsidiary or approved distributor
Internally	U.S. Software Supply Business (SSB) DIGITAL EQUIPMENT CORPORATION 10 Cotton Road Nashua, New Hampshire 030601-1260

Safety

Overview

Any warning or caution that appears in this manual is defined as follows:

WARNING	Contains information to prevent personal injury.
CAUTION	Contains information to prevent damage to equipment.

VORSICHT	Enthält Informationen, die beachtet werden müssen, um den Benutzer vor Schaden zu bewahren.
ACHTUNG	Enthält Informationen, die beachtet werden müssen, um die Geräte vor Schaden zu bewahren.

DANGER	Signale les informations destinées à prévenir les accidents corporels.
ATTENTION	Signale les informations destinées à prévenir la détérioration du matériel.

AVISO	Contiene información para evitar daños personales.
PRECAUCIÓN	Contiene información para evitar daños al equipo.

The warnings and cautions that must be observed for the hardware described in this manual are listed below in English, German, French, and Spanish.

WARNING	Do not attempt to open the module under any circumstances - physical injury may occur. Only qualified service personnel are authorized to open the module.
VORSICHT!	Versuchen Sie auf gar keinen Fall, das Modul zu öffnen - es besteht Verletzungsgefahr. Module dürfen nur von entsprechend ausgebildetem Kundendienstpersonal geöffnet werden.
DANGER!	N'ouvrir cet appareil en aucun cas, sous peine de blessures corporelles. L'ouverture ne doit être effectuée que par un personnel d'entretien qualifié.
¡AVISO!	No se debe abrir el módulo bajo ninguna circunstancia; pueden ocurrir lesiones físicas. Sólo se autoriza al personal cualificado abrir el módulo.

CAUTION	This action deletes all configured settings and replaces them with factory default values. All configuration settings will be lost.
ACHTUNG	Bei diesem Vorgang werden alle Konfigurationseinstellungen gelöscht und die Werkseinstellungen wieder eingesetzt. Alle Konfigurationsdaten gehen verloren.
ATTENTION	Cette action supprime tous les paramètres de configuration et les remplace par des valeurs prédéfinies. Tous les paramètres de configuration seront perdus.
PRECAUCIÓN	Esta intervención borrará todos los parámetros de configuración y los sustituirá por valores por defecto definidos de fábrica. Se perderán todos los parámetros de configuración.

Chapter 1

Product Introduction

Overview

Introduction

This chapter describes the DECswitch 900ET product and its features.

In this chapter

Topic	Page
What is the DECswitch 900ET?	1-2
Features	1-3
Front Panel Features	1-6
Back Panel Features	1-9

What is the DECswitch 900ET?

What is the DECswitch 900ET?

The DECswitch 900ET (also referred to in this manual as the module) is a bridging router. It connects two Token-Ring LANs and one Ethernet LAN. Each LAN interface can be connected either to an external LAN or to a DEChub 900 backplane channel. Only one of the Token Ring interface can be connected to the backplane channel.

The DECswitch 900ET is available in two packages: Multiprotocol (MP) and Internet Protocol (IP). These packages are defined later in this chapter. This module interconnects networks that have both routable and nonroutable protocols. It routes some protocols while bridging others.

You can configure the module in a DEChub 900 MultiSwitch (also referred to in this manual as the DEChub 900) or as a standalone unit in a DEChub ONE docking station.

The Token Ring port is an IEEE 802.5 compliant network interface that supports 4 Megabytes per second and 16 Megabytes per second ring speeds.

Ethernet is Digital's term for its product compatibility with the ISO 8802-3/ANSI/IEEE 802.3 standards and the Ethernet standards for Carrier Sense Multiple Access with Collision Detection (CSMA/CD) local area networks (LANs).

The DECswitch 900ET standards-compliant technology (IEEE 802.1d, 802.2, 802.3) ensures interoperability in multivendor networks.

Features

Your DECswitch 900ET module includes the following features.

Hot Swap

The module's hot swap capability allows you to install or remove the module from a DEChub 900 without turning off the power.

Configuration and Management

The following configuration and management options are available:

- Support for configuration and management through a command line interface in two ways: locally via the setup port in a DEChub ONE docking station or remotely via Telnet in both the DEChub 900 and the DEChub ONE docking station.
- The Auto Select feature senses which external Ethernet interface has the cable connected and activates that interface.
- Upgradeable device firmware (in nonvolatile Flash memory) using Trivial File Transfer Protocol (TFTP).
- Out-of-Band Management (OBM) over Serial Line Internet Protocol (SLIP) through the OBM connector as an alternative to in-band management.
- Support using LAN hopping and launching of Telnet windows via Digital's clearVISN product.
- Configuration and Management via TCP/IP Telnet.
- SNMP Gets and Traps for network monitoring.

Features

Routing Protocols

The following routing protocols are supported:

- IP. The IP routing protocols are as follows:
 - OSPF (Open Shortest Path First)
 - RIP (Routing Information Protocol)
 - EGP (Exterior Gateway Protocol)
 - IS-IS (Integrated Intermediate System to Intermediate System)
 - MOSPF (Multicast Open Shortest Path First)
 - DVMRP (Distance Vector Multicast Routing Protocol)
- IPX
- AppleTalk Phase II
- DECnet Phase IV
- DECnet Phase V/OSI

Bridging

The following bridging options are supported via Adaptive Source Routing Transparent (ASRT) bridging:

- Spanning tree loop detection protocol IEEE 802.1d.
- Source Routing (SR) Bridging.
- Source Routing Translational Bridging (SR -TB).
- High-speed local traffic filtering and forwarding.
- Flexible filtering (source address, destination address, and protocol) for greater network control, increased security and bandwidth utilization, and reduced propagation of network problems.

Token Ring/Ethernet

The following Token Ring and Ethernet support is available:

- Two Token Ring ports and one IEEE 802.3/Ethernet LAN port.
- Translation between Token Ring and IEEE 802.3/Ethernet frame formats for direct, transparent connections.

SNMP





The following SNMP support is available:

- Built-in SNMP agent support for the following RFCs is provided:
 - SNMP management (RFC 1157)
 - Management Information Base - MIB II (RFC 1213)
 - Bridge MIB (RFC 1493)
 - Ethernet MIB (RFC 1398)
 - Token Ring MIB (RFC 1743)
 - OSPF MIB (RFC 1253)
- Manageability using any generic SNMP management application that supports the MIBs listed above.
- SNMP support for Gets and Traps.

Front Panel Features

Table 1-1 describes the LED indicators and connectors on the front panel (Figure 1-1) of the DECswitch 900ET.

Table 1-1: Front Panel Features and Descriptions

Item	Icon/Port	Name	Description
1		Power LED	On = the module has power. Off = the module has no power.
2		Module OK LED	On = the module passed self-test. Off = diagnostic or module failure. Blinking = partial failure.
3		Ethernet Status (ThinWire)	On = Ethernet connected to the DEChub 900 backplane ThinWire. Off = Ethernet not connected to the DEChub 900 backplane ThinWire.
4		Network Activity	On = traffic level on Ethernet port. Off = no traffic on Ethernet port.
5	TKR/0	CS (Connector Select)	On = front panel Token Ring interface selected. Off = not selected.
	TKR/0	BP (BackPlane Select)	On = DEChub 900 backplane Token Ring interface selected. Off = not selected.
	TKR/0	A (Ring A)	On = DEChub 900 backplane ring A selected. Off = not selected.
	TKR/0	B (Ring B)	On = backplane ring B selected. Off = not selected.
	TKR/0	16	On = inserted in ring at 16 Mb per/second. Off = not inserted.
	TKR/0	4	On = inserted in ring at 4 Mb per/second. Off = not inserted.

(Continued)

Front Panel Features

Figure 1-1: Front Panel LEDs and Connectors

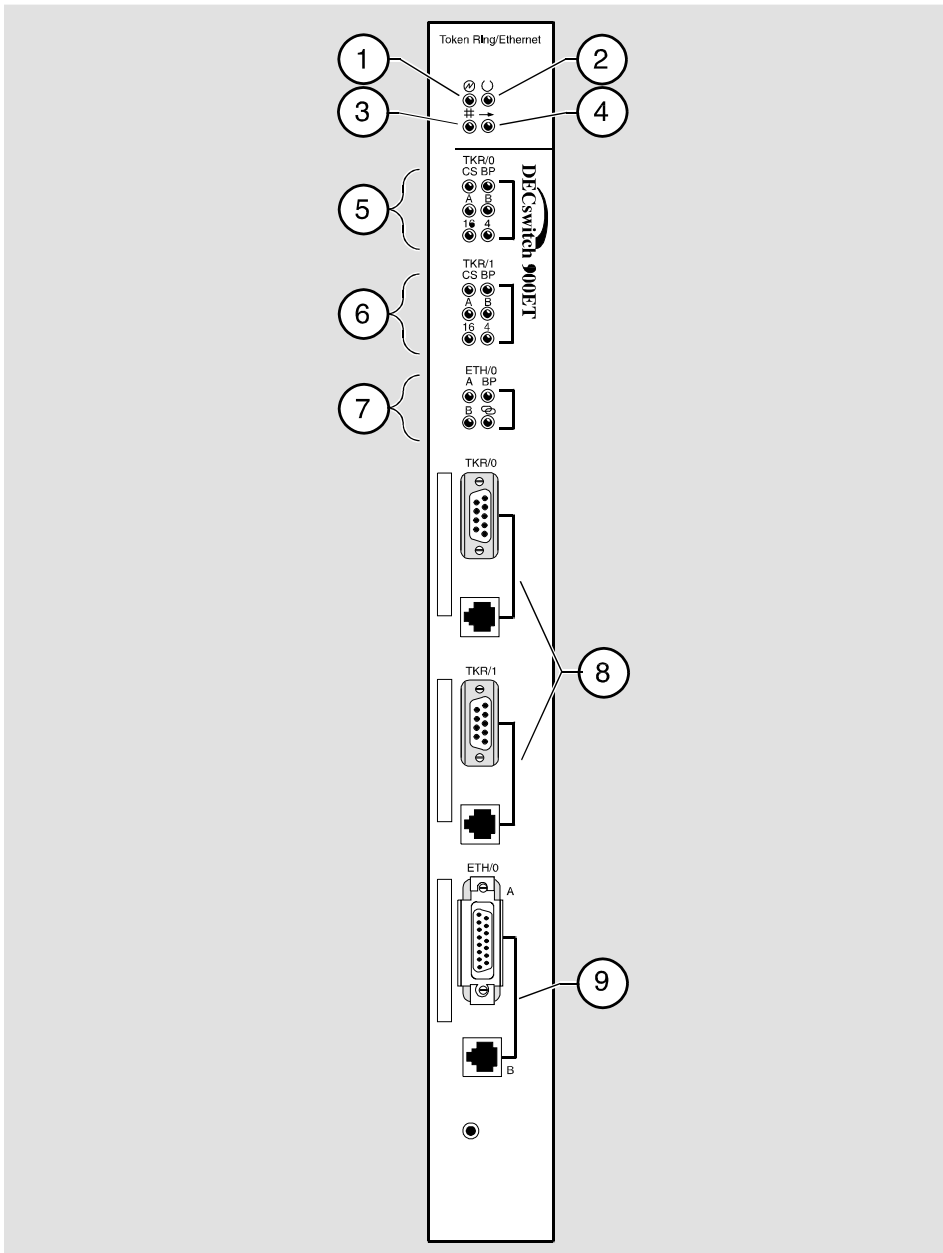

NPG-0290-95F

Front Panel Features

Table 1-1 (Cont.): Front Panel Feature Descriptions

Item	Icon/Port	Name	Description
6	TKR/1	CS (Connector Select)	On = front panel Token Ring interface selected. Off = not selected.
	TKR/1	BP (BackPlane Select)	Reserved for future use.
	TKR/1	A (Ring A)	Reserved for future use.
	TKR/1	B (Ring B)	Reserved for future use.
	TKR/1	16	On = inserted in ring at 16 Mb per/ second. Off = not inserted.
	TKR/1	4	On = inserted in ring at 4 MB per/ second. Off = not inserted.
7	ETH/0	A	On = Front panel AUI Ethernet selected. Blinking = auto sense and waiting for cable insertion. Off = no Ethernet AUI front panel connection.
		B	On = Front panel 10BaseT Ethernet selected. Blinking = auto sense and waiting for cable insertion. Off = no Ethernet 10BaseT front panel connection.
		BP	On = Ethernet is pointed to the DEChub 900 backplane. Off = Ethernet is pointed to the front panel.
		Link 	On = 10BaseT circuit has a link pulse. Off = no 10BaseT link pulse.
8	TKR/0/ TKR/1	Token Ring connections	Supports either UTP or STP interface connections.
9	ETH/0	Ethernet connection	Supports either 10BaseT or AUI 15- pin connections.

Back Panel Features

Table 1-2 lists the features on the back panel (Figure 1-2) of the DECswitch 900ET.

Table 1-2: Back Panel Features and Descriptions

Item	Name	Description
1	Locking tab	Locks the module into the DEChub 900 and engages the power switch.
2	48-pin connector	Provides network and power connections to the module when the module is installed in a DEChub 900 or a DEChub ONE.
3	Grounding bolt	Provides a chassis ground connection between the module and a DEChub 900 or a DEChub ONE.
4	Manufacturing label	Lists the module's part number, serial number, revision level, and power requirements.
5	160-pin connector	Provides network and power connections to the module when the module is installed into a DEChub 900 or a DEChub ONE.
6	Mounting tab	Secures the module when it is installed into a DEChub 900 or a DEChub ONE.
7	Grounding fingers	Provide additional chassis grounding between the module and a DEChub 900 or a DEChub ONE.

Back Panel Features

Figure 1-2: Back Panel Layout

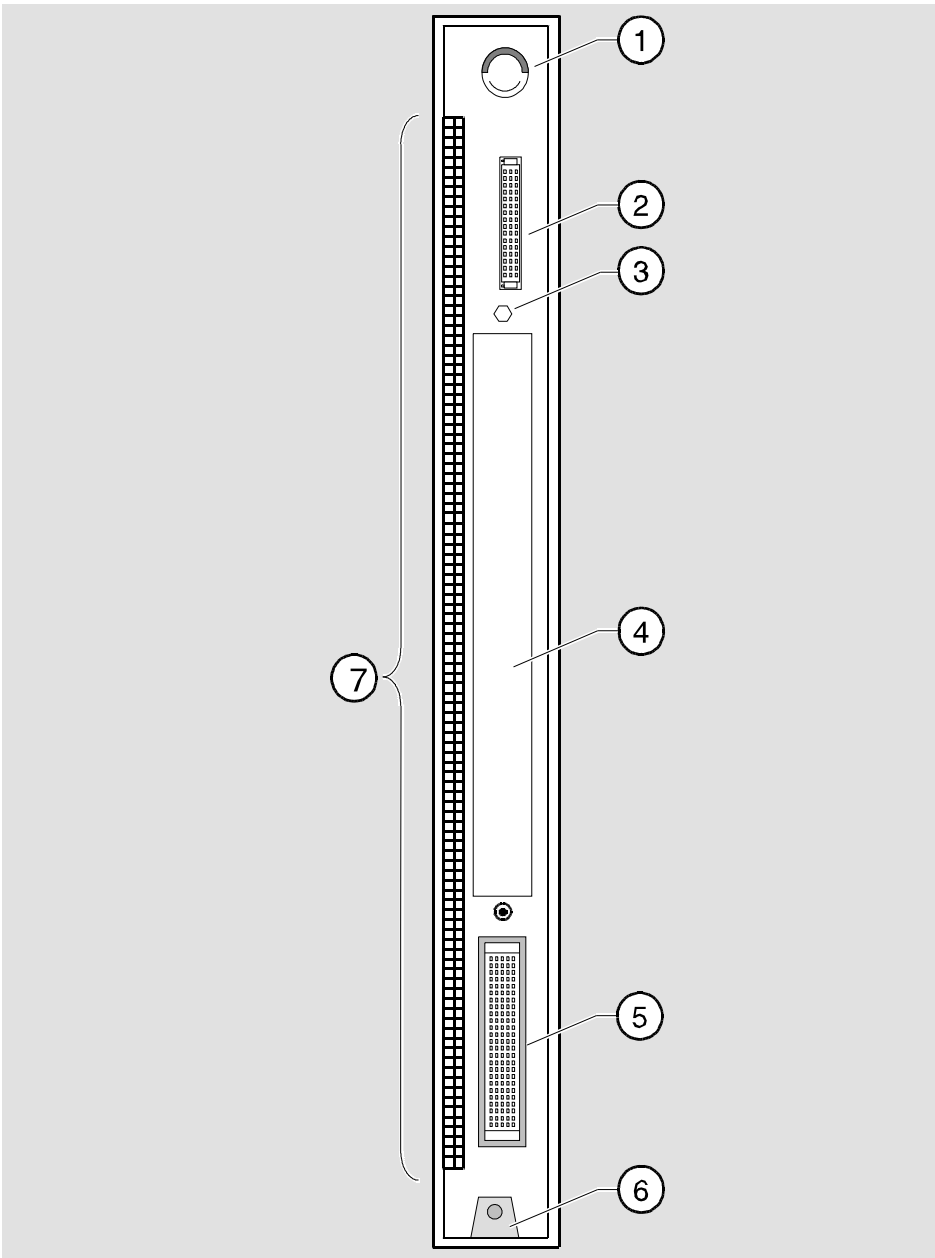

NPG-9723-95F

Chapter 2

Installing the Module

Overview

Introduction

This chapter describes how to install the DECswitch 900ET in a DEChub 900 MultiSwitch. To install a module in a DEChub ONE docking station refer to the *DEChub ONE Installation* manual or the *DECswitch 900ET Quick Start* card.

In this chapter

Topic	Page
Installing the Module in a DEChub 900	2-2
Task 1: Compare the Power Ratings	2-3
Task 2: Seat the Module into the DEChub 900	2-4
Task 3: Verify Initial LED Operation	2-5
Task 4: Connect the Cables	2-6

Installing the Module in a DEChub 900

The DECswitch 900ET hot-swap feature allows you to install the module into a DEChub 900 without turning off power. Seating the module initiates the module's power up sequence if enough power is available.

The following table describes the tasks necessary for installing the module in a DEChub 900.

Task	Description
1	Compare the power ratings.
2	Seat the module into the DEChub 900.
3	Verify initial LED operation.
4	Connect the cables (Optional).

Task 1: Compare the Power Ratings

Compare the module's power ratings (1) with the values shown in the Hub Manager Status display (2) (see Figure 2-1). If the power values on the module's manufacturing label do not exceed the values shown in the Hub Manager status display, go to Task 2.

If the power values on the module's manufacturing label exceed the values shown in the Hub Manager status display, add another power supply to the DEChub 900 (refer to the *DEChub 900 MultiSwitch Owner's Manual*). The 12V power in the DEChub 900 is derived from the 15V source. Although it is listed separately in the product specifications, the 12V requirements are included in the 15V power total.

Figure 2-1: Module Power Ratings

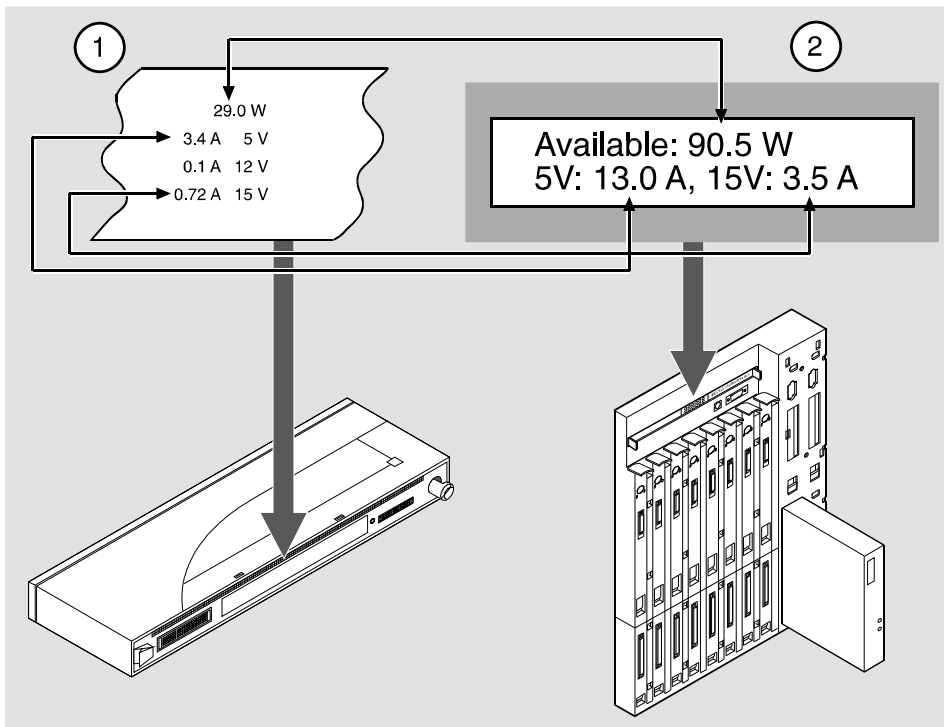

NPG-0317-95F

Task 2: Seat the Module into the DEChub 900

Task 2: Seat the Module into the DEChub 900

To seat the module, perform the following steps (refer to Figure 2-2).

Step	Action
1	Place the module's mounting tab into a mounting slot (1) on the DEChub 900.
2	Pull up the release lever (2) to its unlocked position.
3	Pivot the module on the mounting slot and align the connectors.
4	Firmly push the module onto the backplane connectors.
5	Press down on the release lever (3) to ensure that the module is locked.

Figure 2-2: Seating the Module

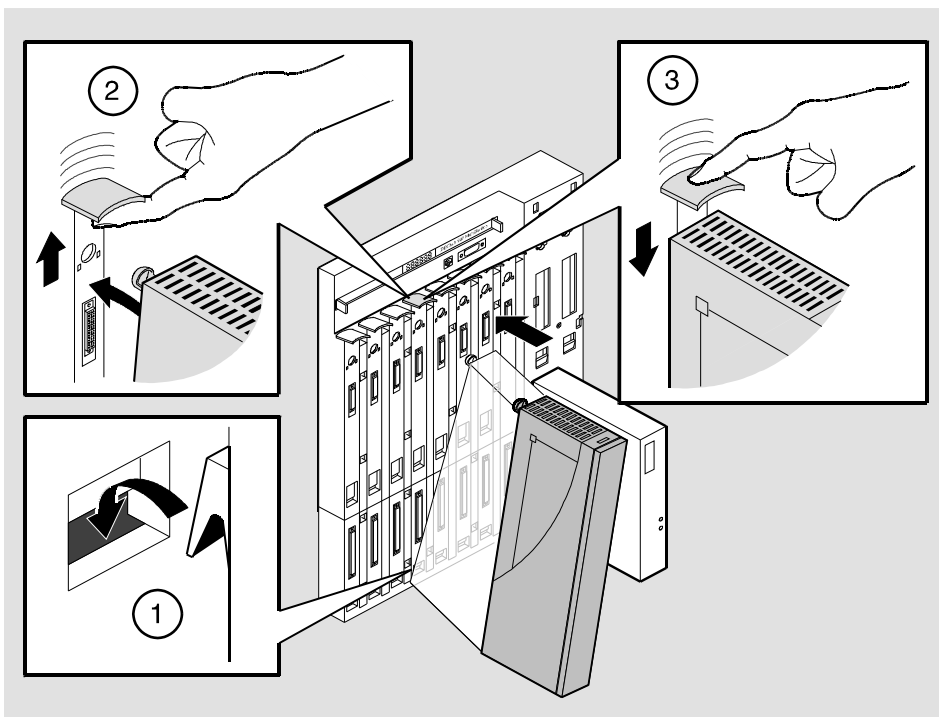

NPG-0004-95F

Task 3: Verify Initial LED Operation

Verify that the module's Power LED and the Module OK LED light within 1 minute (See Figure 2-3). The LEDs light in the following two stages:

Stage	Description
1	The Power LED lights when power is applied to the DEChub 900, then the module performs a self-test. During self-test, various LEDs light as the module cycles through a series of tests.
2	After the module completes self-test, the Module OK LED lights and remains lit. After the module completes its initialization process, the Hub Manager status display shows one of the following:
	<div style="display: flex; justify-content: space-around; align-items: center;"> <div style="border: 1px solid black; padding: 5px; text-align: center;"> DECSwitch 900ET/MP up </div> <div style="border: 1px solid black; padding: 5px; text-align: center;"> DECSwitch 900ET/IP up </div> </div>

NOTE

Refer to Appendix A, Problem Solving, if the LEDs do not operate as described.

Figure 2-3: LED Location

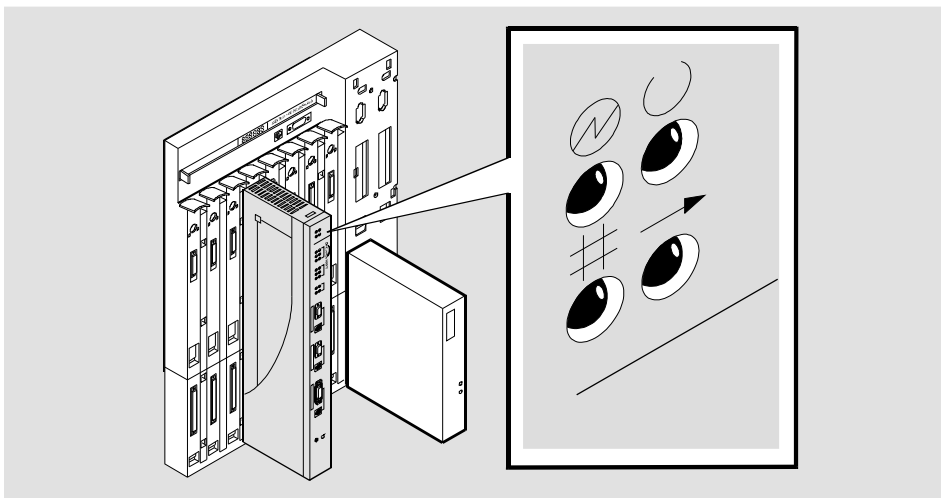

NPG-0291-95F

Task 4: Connect the Cables

Task 4: Connect the Cables

Depending on your network configuration requirements, connect the appropriate Token Ring cables, Ethernet cable and UTP/STP cables. If you are not utilizing the DEChub 900 backplane for network connections, then this task is necessary.

See your network manager if you are not sure which cables to connect.

NOTE

All cables should be installed, tested, and tagged at the site, prior to this installation.

To	Go to Page
Connect 9-pin Token Ring cables	2-7
Connect UTP Token Ring cables	2-8
Connect AUI Ethernet cable	2-9
Connect STP Ethernet cable	2-10

Task 4 (Cont.): Connect the Token Ring (9-pin) Cable

Task 4 (Cont.): Connect the Token Ring (9-pin) Cable

To connect the Token Ring (9-pin) cable connector for the 150-ohm STP, complete the following steps (see Figure 2-4).

Step	Action
1	Insert the plug into the connector.
2	Using a flat headed screwdriver, tighten the two screws on the sides of the connector.

Figure 2-4: Token Ring (9-Pin) Cable Connection

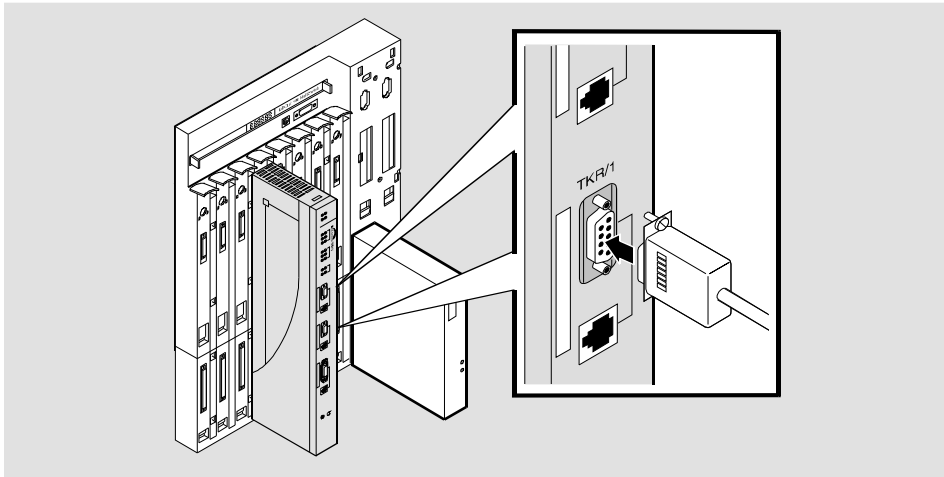

NPG-0292-95F

Task 4 (Cont.): Connecting the Token Ring (UTP) Cable

Task 4 (Cont.): Connecting the Token Ring (UTP) Cable

To connect the UTP cables for the 100-ohm UTP, complete the following steps (see Figure 2-6).

Step	Action
1	Align the release tab on the cable plug (1) with the keyway on the module's Token Ring UTP port connector.
2	Insert the plug into the connector (2), ensuring that the release tab snaps into the locked position.

Figure 2-5: UTP Cable Connection

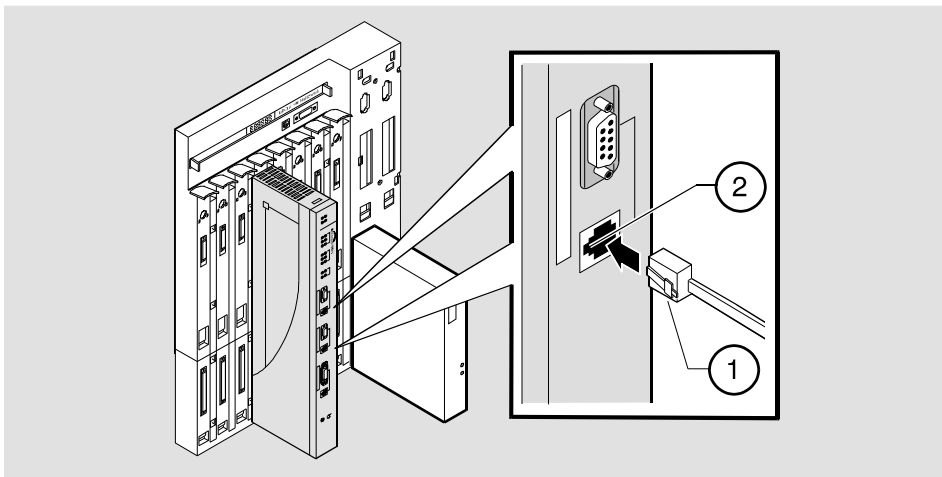

NPG-0318-95F

If you need help determining the appropriate cable type to use, refer to Appendix B, Connector and Pin Assignments.

After module cables are installed, go to Chapter 3, Installing the Setup Port Cable.

Task 4 (Cont.): Connect the AUI Ethernet Cable

To connect the AUI Ethernet cable, complete the following steps (see Figure 2-6).

Step	Action
1	Push the module's AUI connector slide latch up (1) to the unlocked position.
2	Insert the AUI cable plug into the AUI connector.
3	Push the module's AUI connector slide latch down (2) to the locked position.

Figure 2-6: AUI Cable Connection

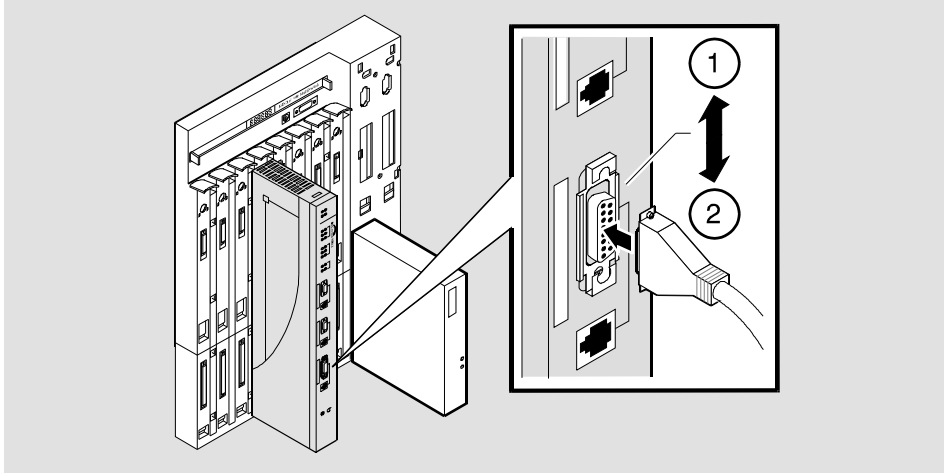

NPG-0297-95F

Task 4 (Cont.): Connecting the Ethernet (10BaseT) Cable

The DECswitch 900ET module uses a straight-through 10BaseT 8-pin MJ port connector for the 100-ohm UTP. Select the appropriate cable type (crossover or straight-through) to ensure that the module's transmit/receive signals connect correctly to the transmitter/receiver of the connected device.

Before connecting the cables to the module, note the following rules.

If the device you are connecting to the module uses . . .	Then use . . .
Straight-through connectors	Crossover cables
Crossover connectors	Straight-through cables

NOTES

- 1 The sum of crossovers must always equal an odd number.
 - 2 Digital's straight-through cables are marked (=); crossover connectors (and cables) are marked (X).
-

If you need help determining the appropriate cable type to use, refer to Appendix B, Connector and Pin Assignments.

Task 4 (Cont.): Connecting the Ethernet (10BaseT) Cable

To connect the 10BaseT cables, complete the following steps (see Figure 2-6).

Step	Action
1	Align the release tab on the cable plug (1) with the keyway on the module's 10BaseT port connector.
2	Insert the plug into the connector (2), ensuring that the release tab snaps into the locked position.

Figure 2-7: 10BaseT Cable Connection

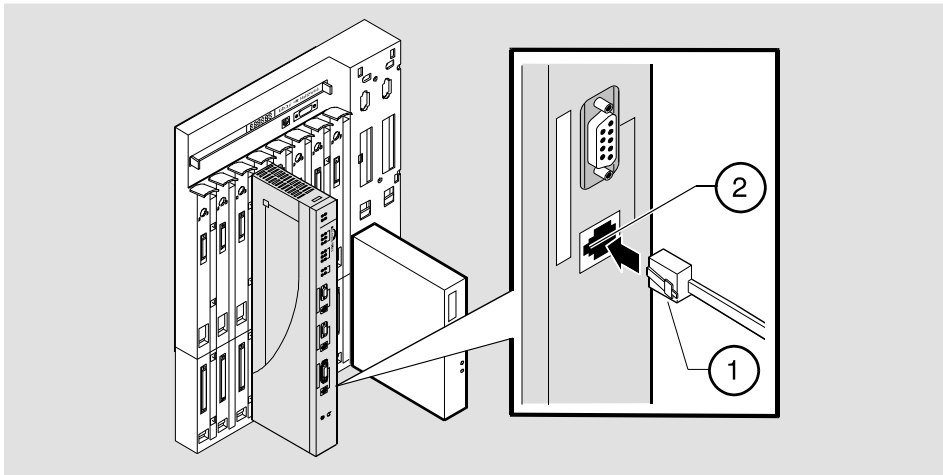

NPB-0438-96F

After module cables are installed, go to Chapter 3, Installing the Setup Port Cable.

Chapter 3

Installing the Setup Port Cable

Overview

Introduction

This chapter describes how to connect the DECswitch 900ET module to the setup port on a DEChub 900 MultiSwitch or a DEChub ONE docking station.

In this chapter

Topic	Page
Signaling Standards	3-2
Setup Port Device Cabling	3-2
Connecting the Setup Port	3-3

Signaling Standards

Signals from the DEChub 900 Hub setup port and from the DEChub ONE docking station setup port conform to the EIA-232D signaling standard at 9600 baud. To the user, the port appears as a data terminal equipment (DTE) device.

The DEChub 900 Hub Manager setup port is compatible with devices that use the EIA-423 signaling standard.

Setup Port Device Cabling

The setup port (see Figure 3-1) on the DEChub 900 MultiSwitch or the DEChub ONE docking station can be connected to a setup port device (a terminal or personal computer), using the following cables and adapters.

If the setup port device is	Use this cable	With this adapter
PC with a 9-pin D-Sub communications port	BN24H-xx ¹	H8571-J
Terminal with a 25-pin D-Sub connector	BN24H-xx ¹	H8575-A
Terminal with a 6-pin MMJ connector	BN24H-xx ¹	Not required.

Legend

¹ xx indicates cable length in meters.

Connecting the Setup Port

To connect the setup port on the DECswitch 900ET module, complete the following steps:

Step	Action
1	Ensure that the transmit and receive baud rates on the setup port device are set to 9600 baud.
2	Connect the setup port device to the setup port connector on either the DEChub 900 or the DEChub ONE docking station (see Figure 3-1).

The following legend identifies the setup port cabling illustrated in Figure 3-1.

Item	Description
1	OBM Port
2	Setup Port
3	Setup Port Device

Connecting the Setup Port

Figure 3-1: Device, Cable and Connector Identification

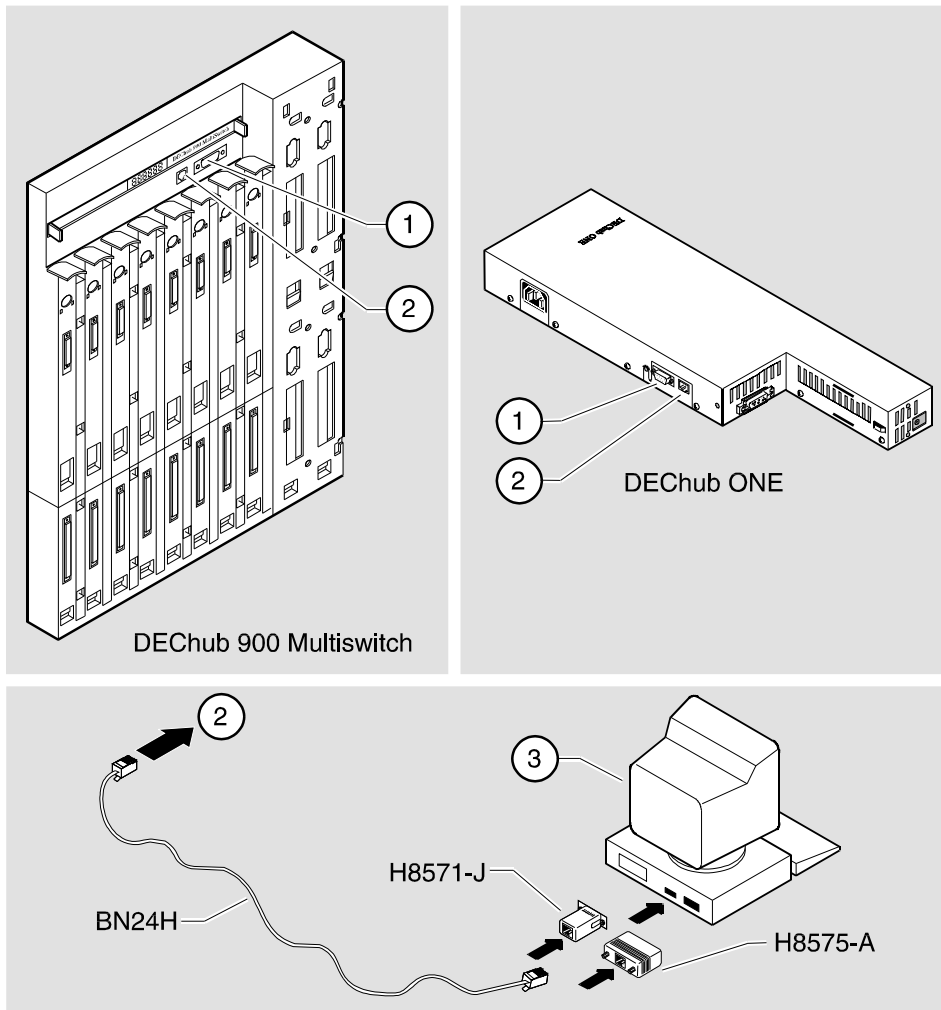

NPG-0233-95F

After all cables are connected, go to one of the following chapters.

To	Go to
Configure the router in a DEChub ONE	Chapter 4
Configure the router in a DEChub 900	Chapter 5

Chapter 4

Setting Up and Configuring the Module in a DEChub ONE

Overview

Introduction

This chapter describes how to set up and configure your DECswitch 900ET when it is installed in a standalone DEChub ONE docking station.

In this chapter

Topic	Page
Accessing the Setup Port	4-2
Using Menus to Setup the Module	4-3
Go to Local Console	4-18
CONFIG Commands	4-21
Configuring Token Ring Port Connections (0 or 1)	4-22
Configuring Ethernet Port Connection	4-23
Configuring OBM	4-24

Accessing the Setup Port

You need to configure your module and make it remotely accessible. This is a two step process.

Step	Action
1	Use menus to assign the following information: <ul style="list-style-type: none">• An IP address• A subnet mask• A default gateway
2	Use Telnet to configure interfaces.

The setup port provides menus that allow you to access the DECswitch 900ET. Setup menus allow you to minimally setup the module for basic connectivity. After setup, you can then configure the module's software using commands provided in the back of this chapter. These commands can be accessed remotely via TCP/IP Telnet, or accessed locally through the setup port on a DEChub ONE docking station.

Examples of the setup screen displays are provided in this section to aid in the description of the setup port and to display the options that are available. Because they are examples only, the displays can vary slightly from the actual screen displays on your setup port device. Boldface type in the screen display examples indicates user input.

To access the setup menus, press the Return key on the setup port device until the DECswitch 900ET/MP INSTALLATION MENU appears.

Using Menus to Setup the Module

This section describes the options that are available from the DECswitch 900ET/MP INSTALLATION MENU when the module is installed in a DEChub ONE docking station. The DEChub ONE's AUI port is not used.

The following example shows the dialog associated with this option when the module is set up with factory defaults.

```
DECswitch900ET/MP
=====
          DECswitch 900ET/MP INSTALLATION MENU

          [1] Restart with Factory Defaults
          [2] Restart with Current Settings
          [3] Show Current Settings
          [4] IP Configuration
          [5] Out-of-Band Port Configuration
          [6] Go to Local Console
          [7] Module-Specific Option

          =====
          Enter selection number:  [n]
          Press Return for Main Menu ...
```

NOTE

The /MP that appears in menus will be replaced with /IP when using the Internet Protocol package.

Using Menus to Setup the Module

If the module was previously configured and restarted, you will see the following screen.

```
DECswitch900ET/MP
=====
                        DECswitch 900ET/MP INSTALLATION MENU
* * * * *
  To fully manage this router telnet to one of the
  following IP addresses or select item [3] below.
  Out-of-Band: Not Configured
  In-Band    : 16.20.20.156
* * * * *
  [1] Restart with Factory Defaults
  [2] Restart with Current Settings
  [3] Go to Local Console
=====
                        Enter selection : [n]
```

The following pages describe the installation menu options.

Topic	Page
[1] Restart with Factory Defaults	4-5
[2] Restart with Current Settings	4-6
[3] Show Current Settings	4-7
[4] IP Configuration	4-8
[5] Out-of-Band Port Configuration	4-13
[6] Go to Local Console <i>or</i> [3] Go to Local Console	4-18
[7] Module-Specific Options	4-16

[1] Restart with Factory Defaults

This option initializes the module's configuration to factory default values by resetting the nonvolatile configuration storage parameters and then restarting the module. (To keep the configured setup, use option [2], or use TFTP to save router configurations on remote host.) Allow approximately one minute for the module to restart.

CAUTION

This action deletes all configured settings and replaces them with factory default values. All configuration settings will be lost.

The following example shows the dialog associated with this option.

```
Enter selection : 1
DECswitch900ET/MP
=====
                RESTART WITH FACTORY DEFAULTS
* * * * *
*           IMPORTANT!   IMPORTANT!   IMPORTANT!           *
* * * * *
* This selection will delete the current configuration      *
* settings and restart the system with the factory default *
* settings. All configuration settings will be lost.       *
* * * * *
=====
                Press Y to confirm [N]:
```

If you selected Y, then the following additional information appears:

```
                Press Y to confirm [N]: Y

About to Initialize CONFIG memory

CONFIG Memory initialized
```

Then the DECswitch 900ET/MP INSTALLATION MENU menu appears.

Using Menus to Setup the Module

[2] Restart with Current Settings

This option restarts the module but leaves the module's configured nonvolatile configuration storage parameters at their current values.

NOTE

Allow approximately 1 minute for the module to restart.

The following example shows the dialog associated with this option.

```
Enter selection: 2
DECswitch900ET/MP
=====
                RESTART WITH CURRENT SETTINGS

This selection will restart your system with the current
configuration settings.
=====
                Press Y to confirm [N] :
```

Using Menus to Setup the Module

[3] Show Current Settings

This option shows the module's current settings. If the module is being configured for the first time, some of the fields are blank.

The following example shows the dialog associated with this option.

```
Enter selection : 3
DECswitch900ET/MP
=====
DECswitch900ET/MP, 2 TR 1 ETH BRouter,#1489,SW=x01.0.051
SysUpTime           : 00:00:52   08 restarts
SNMP Read/Write Community : whitney96
Out-of-Band (OBM) Management RTS : Disabled
Default Gateway     : Not Configured
=====
Interface      IP Address      Subnet Mask      Other Info
Token-Ring
Out-of-Band                               Speed 9600 bps
=====
Token Ring Speed (TKR/0)           : 16 Mbps

NOTE: All settings will be valid after restart of DECswitch 900ET
=====

Press Return for Main Menu ...
```

Using Menus to Setup the Module

[4] IP Configuration

The IP Configuration option provides you with 5 selections.

The following example shows the dialog associated with this option.

```
Enter selection: 4
DECswitch900ET/MP
=====
IP CONFIGURATION
* * * * *
* Configuration will not take effect until module is *
* restarted. *
* * * * *
[1] Set SNMP Read/Write Community
[2] Set In-Band Interface IP Address
[3] Set Out-of-Band Interface IP Address
[4] Set Default Gateway
[5] Return to Main Menu
=====
Enter selection : [n]
```

The following pages describe the IP Configuration options.

Topic	Page
[1] Set SNMP Read/Write Community	4-9
[2] Set In-Band Interface IP Address	4-10
[3] Set Out-of-Band Interface IP Address	4-11
[4] Set Default Gateway	4-12

[4] IP Configuration (Cont.)

[1] Set SNMP Read/Write Community

This option prompts you to enter the module's SNMP read/write community name.

The following example shows the dialog associated with this option.

```
Enter selection: 1

DECswitch900ET/MP
=====
                SET SNMP READ/WRITE COMMUNITY

Format:  The format for a community name is a string,
         consisting of 4 to 31 printable ASCII characters,
         that describes the relationship between an SNMP
         agent and one or more SNMP managers. The string
         defines the authentication mechanism that is employed
         to validate the use of the community by the sending
         SNMP entity.
=====
Enter the community string [ ]: whitney95

                SNMP Read/Write community string set.

Press Return for IP Configuration Menu ...
```

Using Menus to Setup the Module

[4] IP Configuration (Cont.)

[2] Set In-Band Interface IP Address

This option prompts you to change or enter the IP address and subnet mask for the in-band interface. You can only configure one in-band interface at a time. The module does not need to be configured with a subnet mask for SNMP and Telnet communications with management stations located on the same subnet as the module.

The format for these values is the standard 4-octet dotted decimal notation, where each octet of the address is represented as a decimal value, separated by a decimal point (.).

The following example shows the dialog associated with this option.

```
Enter selection: 2
DECswitch900ET/MP
=====
                IN-BAND INTERFACE IP ADDRESS CONFIGURATION
=====
Format:      The standard 4 octet dotted decimal notation in which
              each octet of the address is represented as a decimal
              value, separated by a '.' character.

              example: 16.20.40.156

              To delete the address, enter 0 in the appropriate address
              field.
=====
Interface    IP Address      Subnet Mask      Other Info
Token Ring
Out-of-Band                                Speed 9600 bps
=====
Port Number (1-3) [ ] : 1
IP address [ ] : 16.20.40.156
Subnet Mask [ ] : 255.255.255.0
Press Return for IP Configuration Menu ...
```

NOTE

In this menu, port numbers are labeled 1-3. When using commands to configure, they are labeled 0-2.

[4] IP Configuration (Cont.)

[3] Set Out-of-Band Interface IP Address

This option prompts you to change or enter the IP address and subnet mask for the out-of-band management (OBM).

This feature allows you to manage your module through the OBM port located on the DEChub ONE docking station as an alternative to normal in-band management. To enable out-of-band management, you need to assign an OBM IP address and select an OBM port speed from the DECswitch 900ET/MP INSTALLATION MENU.

The module does not need to be configured with a subnet mask for SNMP and Telnet communications with management stations located on the same subnet as the module.

The following example shows the dialog associated with this option.

```

Enter selection: 3
DECswitch900ET/MP
=====
OUT-OF-BAND INTERFACE IP ADDRESS CONFIGURATION

Format:  The standard 4 octet dotted decimal notation in which
         each octet of the address is represented as a decimal
         value, separated by a '.' character.

         example: 16.20.40.156

         To delete the address, enter 0 in the appropriate address
         field.

-----
Interface   IP Address   Subnet Mask   Other Info
Token Ring  16.20.22.20  255.255.255.0
Out-of-Band                               Speed 9600 bps
-----

IP address [ ] : 16.126.16.114

Subnet Mask [ ] : 255.255.0.0

Press Return for IP Configuration Menu ...
    
```

Using Menus to Setup the Module

[4] IP Configuration (Cont.)

[4] Set Default Gateway

This option sets the default gateway address, if necessary, for the in-band interface. This is the address of a router that the module will use when communicating to a remote host. The default gateway address must be an address in the same subnet as your in-band address.

The following example shows the dialog associated with this option.

```
Enter selection : 4
DECswitch900ET/MP
=====
      SET IN-BAND INTERFACE DEFAULT GATEWAY ADDRESS

Format:  The standard 4 octet dotted decimal notation in which
         each octet of the address is represented as a decimal
         value, separated by a '.' character.

         example: 16.20.40.156

         To delete the address, enter 0 in the appropriate address
         field.
=====
      Default Gateway [ ] : 16.126.16.254

      Default Gateway Address Set.

      Press Return for IP Configuration Menu ...
```

[5] Out-of-Band Port Configuration

This option lets you set the out-of-band port speed.

NOTE

The port speeds at both ends of the communications link must be identical.

The following example shows the dialog associated with this option.

```
Enter selection: 5
DECswitch900ET/MP
=====
OUT-OF-BAND PORT CONFIGURATION
* * * * *
* Configuration will not take effect until module is *
* restarted. *
* * * * *

[1] Set Port Speed
[2] Enable/Disable RTS
[3] Return to Main Menu

=====

Enter selection : [n]
```

The following pages describe the out-of-band port options.

Topic	Page
[1] Set Port Speed	4-14
[2] Enable / Disable RTS	4-15

Using Menus to Setup the Module

[5] Out-of-Band Port Configuration (Cont.)

[1] Set Port Speed

This option lets you select the out-of-band port speed. The factory default for this option is 9600 baud. The OBM port speed that you select must match the speed of your OBM device.

The following example shows the dialog associated with this option.

```
Enter selection: 1

DECswitch900ET/MP
=====
      SET OUT-OF-BAND MANAGEMENT INTERFACE PORT SPEED

      [1]  2400 baud
      [2]  9600 baud
      [3] 38400 baud

=====
Enter selection [2] (9600): [n]

      OBM port speed set

Press Return for Main Menu ...
```

[5] Out-of-Band Port Configuration (Cont.)

[2] Enable/Disable RTS

This option allows you to enable or disable Request to Send (RTS). The factory default for this option is Disabled.

The following example shows the dialog associated with this option, if RTS is disabled.

```
Enter selection : 2
DECswitch 900ET/MP
=====
                ENABLE / DISABLE OUT-OF-BAND PORT RTS

Enable/Disable request to send (RTS) option allows additional control
to modem communications. When the RTS option is disabled the RTS
signal on the OBM port is asserted after self-test is completed and
left asserted. When the RTS option is Enabled the RTS signal is
asserted only when there is data to be transmitted and deasserted
after the data has been transmitted.

=====
RTS is Disabled. Would you like to ENABLE RTS? [N]

                Press Return for OBM Configuration Menu...
```

If RTS is enabled, the screen shows RTS is Enabled. Would you like to DISABLE RTS?.

Using Menus to Setup the Module

[7] Module-Specific Options

This option lets you select the Token-Ring port speed.

The following example shows the dialog associated with this option.

```
Enter selection: 7

DECswitch900ET/MP
=====
DECswitch 900 SPECIFIC MENU

[1] Set Token-Ring Speed
[2] Return to Main Menu

=====

Enter selection : [n]
```

The following menu shows the DECswitch 900ET specific menu options.

[7] Module-Specific Option (Cont.)

[1] Set Token-Ring Speed

This option lets you set the Token-Ring speed. The factory default for this option is 16 Megabytes per second. The values are either 4 Megabytes per second or 16 Megabytes per second.

The following example shows the dialog associated with this option.

```
Enter selection: 1

Enter Token-Ring Speed for TR0 (4, 16) [16] :

Press Return for DECswitch 900ET Specific Menu ...
```

Go to Local Console

You must configure the module before it is operational. There are two options that you can use to do this.

The first option runs a quick configuration interactive question and answer dialog. This (qconfig) method allows fast configuration of interfaces, basic bridging, and routing protocol configuration.

The second option allows you to configure the module using commands to configure interfaces, bridging, and routing protocols (for example, IPX and IP).

Go to one of the subsections listed in the following table:

If you selected	Go to Page
[6] Go to Local Console (Qconfig)	4-18
[3] Go to Local Console (Commands)	4-20

[6] Go To Local Console (Qconfig)

This selection runs quick configuration. If you reset to factory default and go to local console without having configured the module via the installation menu, you automatically enter the **qconfig** process.

You can exit quick configuration and accept the changes you made by typing: **quit**.

The system displays the following messages:

```
Quick Config Done
Config (Only)>restart
Are you sure you want to restart the router (Yes, [No]) :
```

Go to Local Console

If you type **yes**, then a submenu of the DECswitch 900ET/MP INSTALLATION MENU displays.

```
DECswitch900ET/MP
=====
                DECswitch 900ET/MP INSTALLATION MENU

* * * * *
To fully manage this device telnet to one of the following IP
addresses or select item [3] below.
Out-of-Band  :Not Configured
In-Band      :16.20.20.20

* * * * *

                [1] Restart with Factory Defaults
                [2] Restart with Current Settings
                [3] Go to Local Console

=====
                Enter selection:  [n]
```

If you need to review information about this menu, the following pages describe the menu options.

Topic	Page
[1] Restart with Factory Defaults	4-5
[2] Restart with Current Settings	4-6
[3] Go to Local Console	4-20

Go to Local Console

[3] Go To Local Console (Commands)

If you have configured the module then the following menu appears. Select [3] Go To Local Console to modify the configuration.

```
DECswitch900ET/MP
=====
                DECswitch 900ET/MP INSTALLATION MENU
* * * * *
*   To fully manage this router Telnet to one of its IP   *
*   addresses or select item [3] below.                   *
*   Out-of-Band: Not Configured                          *
*   In-Band      : 16.20.126.20                          *
* * * * *
                [1] Restart with Factory Defaults
                [2] Restart with Current Settings
                [3] Go to Local Console
=====
                Enter selection:  3
```

The system displays copyright statements and the following prompt:

```
MOS Operator Control
*
```

After the system prompt (*) appears, go to the section titled CONFIG Commands.

CONFIG Commands

This section describes commands that are unique to the DECswitch 900ET. Other CONFIG commands that can be included in the configuration of the DECswitch 900ET can be found in the *Distributed Routing System Software Guide*. You can use two methods to configure the module: through Telnet (using commands) or setup port on the DEChub ONE (via a menu).

NOTE

You can configure the module at any time using Quick Configuration, by typing **qconfig** at the `Config>` prompt.

To configure the module using CONFIG commands, refer to the following steps.

Step	Action								
1	At the system prompt (*), enter: talk 6 or t 6								
2	Select one of the following options.								
	<hr/>								
	<table><thead><tr><th>Option</th><th>Page</th></tr></thead><tbody><tr><td>Configure Token Ring</td><td>4-22</td></tr><tr><td>Configure Ethernet Connection</td><td>4-23</td></tr><tr><td>Configure OBM</td><td>4-24</td></tr></tbody></table>	Option	Page	Configure Token Ring	4-22	Configure Ethernet Connection	4-23	Configure OBM	4-24
Option	Page								
Configure Token Ring	4-22								
Configure Ethernet Connection	4-23								
Configure OBM	4-24								

Configuring Token-Ring Port Connection (0 or 1)

Configuring Token-Ring Port Connection (0 or 1)

This section describes how to configure the Token-Ring port 0 or port 1 for front connections (connectors on the front of the module).

Step	Action
1	At the <code>Config></code> prompt enter: net 0 or net 1 Example: <code>Config>net 1</code>
2	At the <code>TKR config></code> prompt enter either: speed 4 or speed 16 Example: <code>TKR config>speed 16</code>

To Exit and Restart

When you modify parameters, you must restart the router for the change to take effect. Enter the following three commands in the order shown:

At the prompt		Enter the Command
<code>ETH Config></code>	(ETH Config prompt)	exit
<code>Config></code>	(CONFIG prompt)	control/p
*	(System prompt)	restart

If you need to configure additional software, refer to the *Distributed Routing System Software Guide*.

Configuring Ethernet Port 2 Connection

This section describes how to configure the Ethernet port 2 configuration for front connections (connector on the front of the module only). The port on the DEChub ONE is not supported. This does not apply when port 2 is configured to run on the DEChub 900 backplane.

Step	Action
1	At the <code>Config></code> prompt enter: net 2 Example: <code>Config>net 2</code>
2	At the <code>ETH config></code> prompt enter either: connect AUI connect RJ45 (10BaseT) Auto-Config Example: <code>ETH config> connect AUI</code>

To Exit and Restart

When you modify parameters, you must restart the module for the change to take effect. Enter the following three commands in the order shown:

At the prompt	Enter the Command
<code>ETH Config></code>	(ETH Config prompt) exit
<code>Config></code>	(CONFIG prompt) control/p
*	(System prompt) restart

If you need to configure additional software, refer to the *Distributed Routing System Software Guide*.

Configuring OBM

This section describes how to set the OBM IP address and speed. After entering **talk 6**, at the `Config>` prompt you can set the following OBM parameters as follows:

Parameter	Description	Default
set obm ip-address Example: set obm 16.40.156.20	Sets the out-of-band management port IP-address (for example, 16.40.156.20).	current IP-address
set obm speed Example: set obm 38400	Sets the OBM port speed (2400, 9600, or 38400 bps).	9600
set obm RTS Example: set obm rts	Enables or disables RTS.	disabled

To Exit and Restart

When you modify parameters, you must restart the router for the change to take effect. Enter the following commands

At the prompt		Enter the Command
Config>	(CONFIG prompt)	control/p
*	(System prompt)	restart

If you need to configure additional software, refer to the *Distributed Routing System Software Guide*.

Chapter 5

Configuring the Module in a DEChub 900

Overview

Introduction

This chapter describes how to configure your DECswitch 900ET when it resides in a DEChub 900 MultiSwitch.

In this chapter

Topic	Page
Accessing the Setup Port	5-2
DEChub 900 MultiSwitch Installation Menu	5-3
Using Menus to Setup the Module	5-5
Using Telnet to Configure Interfaces	5-17
Configuring Token Ring Port Connections (0 or 1)	5-19
Configuring Ethernet Port Connection	5-20
Configuring OBM	5-21

Accessing the Setup Port

You need to configure your module and make it remotely accessible. This is a two step process.

Step	Action
1	Use menus to assign the following information: <ul style="list-style-type: none">• An IP address• A subnet mask• A default gateway
2	Use Telnet to configure interfaces.

The setup port provides menus that allow you to access the DECswitch 900ET. Setup menus allow you to minimally setup the module for basic connectivity. After setup, you can then configure the module's software using commands provided in the back of this chapter. These commands can be accessed remotely via TCP/IP Telnet.

Examples of the setup screen displays are provided in this section to aid in the description of the setup port and to display the options that are available. Because they are examples only, the displays can vary slightly from the actual screen displays on your setup port device. Boldface type in the screen display examples indicates user input.

To access the setup menus, press the Return key on the setup port device until the DECswitch 900ET/MP INSTALLATION MENU appears.

DEChub 900 MultiSwitch Installation Menu

Examples of the setup screen displays are provided in this section to aid in the description of the setup port and to display the options that are available. Because they are examples only, the displays can vary slightly from the actual screen displays on your setup port device.

The following screen is an example of the DEChub 900 MultiSwitch INSTALLATION MENU.

To access the module's set up screen, you must choose option [9] Start Redirect Mode.

The following example shows the dialog associated with this option.

```
DEChub 900 MultiSwitch
=====
      DEChub 900 MultiSwitch INSTALLATION MENU

      [1] Reset with Factory Defaults
      [2] Reset with Current Settings
      [3] Show Current Settings
      [4] Configure IP...
      [5] Dump Error Log
      [6] Downing Upgrade
      [7] Configure Out-of-Band Port...
      [8] Start Event Display Mode
      [9] Start Redirect Mode...

=====
      Enter selection number: 9
```

[9] Start Redirect Mode

The Start Redirect Mode option redirects the DEChub 900 MultiSwitch Hub Manager set-up port to the set-up port of any network module (such as the DECswitch 900ET) that is installed into the DEChub 900 MultiSwitch. Choosing this option allows you to set-up or obtain the status of an installed network module by accessing the specified network module's installation menu.

After you choose the Start Redirect Mode option from the DECswitch 900ET/MP INSTALLATION MENU, the screen display prompts you for a slot number (8) as shown in the following example. After you enter the number of the slot in which the DECswitch 900ET is installed, the console is redirected to this slot.

NOTE

The slot number may change to reflect the slot number in which your module is installed.

The following example shows the dialog associated with this option.

```
Enter selection number : 9
Enter the slot number for redirection (1-8): 8
Console redirected to 8: DECswitch900ET/MP
Attempting connection [Ctrl/C to abort] ...
```

The following table describes the installation menu options.

If ...	Go to Page
The redirection is successful after you press the Return key, the DECswitch 900ET/MP INSTALLATION MENU appears on your screen.	5-5
The module was previously configured and restarted, the menu provides only two options.	5-6

Using Menus to Setup the Module

This section describes the options that are available from the DECswitch 900ET/MP INSTALLATION MENU when the module is installed in the DEChub 900 MultiSwitch.

The following example shows the dialog associated with this option.

```
DECswitch900ET/MP - slot 8
=====
                DECswitch 900ET/MP INSTALLATION MENU

                [1] Restart with Factory Defaults
                [2] Restart with Current Settings
                [3] Show Current Settings
                [4] IP Configuration
                [5] Module-Specific Options

                [Ctrl/C] Return to the Hub Manager Menu
=====
                Enter selection:  [n]
```

The following table describes the installation menu options.

Topic	Page
[1] Restart with Factory Defaults	5-7
[2] Restart with Current Settings	5-8
[3] Show Current Settings	5-9
[4] IP Configuration	5-10
[5] Module-Specific Option	5-15

NOTE

The /MP that appears in menus will be replaced with /IP when using the Internet Protocol package.

Using Menus to Setup the Module

If the module was previously configured and restarted, the menu provides only two options, as shown in the following example.

```
DECswitch900ET/MP - slot 8
=====
                DECswitch 900ET/MP INSTALLATION MENU
* * * * *
    To fully manage this device telnet to one of the
    following IP addresses.
    Out-of-Band : 16.20.40.20
    In-Band     : 16.20.10.156
* * * * *

    [1] Restart with Factory Defaults
    [2] Restart with Current Settings

    [Ctrl/C] Return to the Hub Manager Menu
=====
                Enter selection : [n]
```

[1] Restart with Factory Defaults

This option restarts the module, causing the module's configured nonvolatile configuration storage parameters to be initialized to factory default values. (To retain current values, use option [2] Restart with Current Settings.) Allow approximately one minute for the module to restart and complete self-test.

CAUTION

This action deletes all configured settings and replaces them with factory default values. All configuration settings will be lost.

The following example shows the dialog associated with this option.

```
Enter selection : 1
DECswitch900ET/MP - slot 8
=====
                RESTART WITH FACTORY DEFAULTS
* * * * *
*           IMPORTANT!   IMPORTANT!   IMPORTANT!           *
* * * * *
* This selection will delete the current configuration      *
* settings and restart the system with the factory default *
* settings. All configuration settings will be lost.      *
* * * * *
=====

                Press Y to confirm [N] :
                Module Removed! Connection Closed!

                Press Return for Main Menu ...
```

Using Menus to Setup the Module

[2] Restart with Current Settings

This option restarts the module but leaves the module's configured nonvolatile configuration storage parameters at their current values.

NOTE

Allow approximately 1 minute for the module to Restart.

The following example shows the dialog associated with this option.

```
Enter selection: 2
DECswitch900ET/MP - slot 8
=====
                RESTART WITH CURRENT SETTINGS
This selection will restart your system with the current
configuration settings.
=====
                Press Y to confirm [N] : [n]
                Module Removed! Connection Closed!
                Press Return for Main Menu ...
```

Using Menus to Setup the Module

[3] Show Current Settings

This option shows the module's current settings. If the module is being configured for the first time, some of the fields will be blank.

The following example shows the screen display associated with this option.

```
Enter selection : 3

DECswitch900ET/MP - slot 8
=====
DECswitch900ET/MP, 2 TR 1 ETH BRouter,#1489,SW=X01.0.051
SysUpTime           : 00:00:18   8 restarts
SNMP Read/Write Community : Not Available
Default Gateway     : Not Configured
=====
Interface   IP Address   Subnet Mask   Other Info
Token-Ring
Out-of-Band
=====
Token Ring Speed (TKR/0)           : 16 Mbps

NOTE: All settings will be valid after restart of DECswitch 900ET
=====

Press Return for Main Menu ...
```

Using Menus to Setup the Module

[4] IP Configuration

The IP Configuration option provides you with 5 selections.

The following example shows the dialog associated with this option.

```
Enter selection: 4

DECswitch900ET/MP - slot 8
=====
                          IP CONFIGURATION
* * * * *
*      Configuration will not take effect until module is      *
*      restarted.                                              *
* * * * *

      [1] Set SNMP Read/Write Community
      [2] Set In-Band Interface IP Address
      [3] Set Out-of-Band Interface IP Address
      [4] Set Default Gateway
      [5] Return to Main Menu

=====

Enter selection : [n]
```

The following pages describe IP Configuration options.

Topic	Page
[1] Set SNMP Read/Write Community	5-11
[2] Set In-Band Interface IP Address	5-12
[3] Set Out-of-Band Interface IP Address	5-13
[4] Set Default Gateway	5-14

[4] IP Configuration (Cont.)

[1] Set SNMP Read/Write Community

This option prompts you to enter the module's read/write community name.

The following example shows the dialog associated with this option.

```
Enter selection: 1

DECswitch900ET/MP - slot 8
=====
          SET SNMP READ/WRITE COMMUNITY

Format: The format for a community name is a string,
        consisting of 4 to 31 printable ASCII characters,
        that describes the relationship between an SNMP
        agent and one or more SNMP managers. The string
        defines the authentication mechanism that is employed
        to validate the use of the community by the sending
        SNMP entity.
=====

Enter the community string []: whitney95

          SNMP Read/Write community string set.

          Press Return for IP Configuration Menu ...
```

Using Menus to Setup the Module

[4] IP Configuration (Cont.)

[2] Set In-Band Interface IP Address

This option prompts you to change or enter the IP address and subnet mask for the in-band interface. The module does not need to be configured with a subnet mask for SNMP communications with management stations located on the same subnet as the module.

The format for these values is the standard 4-octet dotted decimal notation, where each octet of the address is represented as a decimal value, separated by a decimal point (.).

The following example shows the dialog associated with this option.

```
Enter selection: 2

DECswitch900ET/MP - slot 8
=====
                IN-BAND INTERFACE IP ADDRESS CONFIGURATION
=====
Format: The standard 4 octet dotted decimal notation in which
each octet of the address is represented as a decimal
value, separated by a '.' character.

                example: 16.20.40.156

To delete the address, enter 0 in the appropriate address
field.

-----
Interface      IP Address      Subnet Mask      Other Info
Token-Ring
Out-of-Band
-----
=====
                Port Number (1-3)[ ] : 1
                IP address [ ] : 16.20.40.20
                Subnet Mask [ ] : 255.255.225.0
                Press Return for IP Configuration Menu ...
```

NOTE

In this menu, port numbers are labeled 1-3. Elsewhere, they are labeled 0-2.

[4] IP Configuration (Cont.)

[3] Set Out-of-Band Interface IP Address

This option prompts you to change or enter the IP address and subnet mask for the out-of-band interface. The module does not need to be configured with a subnet mask for SNMP communications with management stations located on the same subnet as the module.

The format for these values is the standard 4-octet dotted decimal notation, where each octet of the address is represented as a decimal value, separated by a decimal point (.).

The following example shows the dialog associated with this option.

```
Enter selection: 3

DECswitch900ET/MP - slot 8
=====

OUT-OF-BAND INTERFACE IP ADDRESS CONFIGURATION

Format: The standard 4 octet dotted decimal notation in which
each octet of the address is represented as a decimal
value, separated by a '.' character.

example: 16.20.80.40

To delete the address, enter 0 in the appropriate address
field.

-----
Interface      IP Address      Subnet Mask      Other Info
Token-Ring     16.20.40.20     255.255.255.0
Out-of-Band
-----
=====

IP address [ ] : 16.20.54.20
Subnet Mask [ ] : 255.255.156.0
Press Return for IP Configuration Menu ...
```

Using Menus to Setup the Module

[4] IP Configuration (Cont.)

[4] Set Default Gateway

This option sets the default gateway, if necessary. This is the address of a router that the module will use when communicating to a remote host. The default gateway address must be in the same subnet as your in-band address.

The following example shows the dialog associated with this option.

```
Enter selection : 4

DECswitch900ET/MP - slot 8
=====

      SET IN-BAND INTERFACE DEFAULT GATEWAY ADDRESS

Format: The standard 4 octet dotted decimal notation in which
each octet of the address is represented as a decimal
value, separated by a '.' character.

      example: 16.20.40.156

To delete the address, enter 0 in the appropriate address
field.
=====

      Default Gateway [ ] : 16.156.126.89

      Default Gateway Address Set.

      Press Return for IP Configuration Menu ...
```

If you need to configure additional software, refer to the *Distributed Routing Software System Software Guide*.

Using Menus to Setup the Module

[5] Module-Specific Option

This option lets you select the Token Ring port speed.

The following example shows the dialog associated with this option.

```
Enter selection: 5
DECSwitch900ET/MP
=====
DECSwitch 900ET SPECIFIC MENU
[1] Set Token-Ring Speed
[2] Return to Main Menu
=====
Enter selection : [n]
```

Using Menus to Setup the Module

[5] Module-Specific Option

[1] Set Token-Ring Speed

This option lets you set the Token Ring speed. The factory default for this option is 16 Megabytes per second.

The following example shows the dialog associated with this option.

```
Enter selection : 1

Enter Token Ring Speed For TKR/0 (4,16) [16] : [n]

Press Return for DECswitch 900ET Specific Menu ...
```

Using Telnet to Configure Interfaces

You must configure the module before it is operational. To do this you must use Telnet. Once the system prompt displays, you can use one of two options to configure.

The first option runs a quick configuration interactive question and answer dialog. This (qconfig) method allows fast configuration of interfaces, basic bridging, and routing protocol configuration.

The second option allows you to configure the module using commands to configure interfaces, bridging, and routing protocols.

Go to one of the subsections listed in the following table:

If you selected	Go to Page
Using Qconfig	5-17
Using Commands	5-18

Using Qconfig

This selection runs quick configuration. If the module has never been configuring, you automatically enter the **qconfig** process.

You can exit quick configuration and accept the changes you made by typing: **quit**.

An example of the system display is as follows.

```
Quick Config Done
Config (Only)>restart
Are you sure you want to restart the router (Yes, [No]) :

MOS Operator Control
*
```

Using Commands

This section describes commands that are unique to the DECswitch 900ET. Other CONFIG commands that can be included in the configuration of the DECswitch 900ET can be found in the *Distributed Routing System Software Guide*. You can configure the module using Telnet (via commands).

NOTE

You can configure the module at any time using Quick Configuration, by typing **qconfig** at the `Config>` prompt.

To configure the module using CONFIG commands, refer to the following steps.

Step	Action								
1	At the system prompt (*), enter: talk 6 or t 6								
2	Select one of the following options.								
	<hr/>								
	<table><thead><tr><th>Option</th><th>Page</th></tr></thead><tbody><tr><td>Configure Token Ring</td><td>5-19</td></tr><tr><td>Configure Ethernet Connection</td><td>5-20</td></tr><tr><td>Configure OBM</td><td>5-21</td></tr></tbody></table>	Option	Page	Configure Token Ring	5-19	Configure Ethernet Connection	5-20	Configure OBM	5-21
Option	Page								
Configure Token Ring	5-19								
Configure Ethernet Connection	5-20								
Configure OBM	5-21								

Configuring Token-Ring Port Connection (0 or 1)

This section describes how to configure the Token-Ring port 0 or port 1 for front connections (connectors on the front of the module).

Step	Action
1	At the <code>Config></code> prompt enter: net 0 or net 1 Example: <code>Config>net 1</code>
2	At the <code>TKR config></code> prompt enter either: speed 4 or speed 16 Example: <code>TKR config>speed 16</code>

To Exit and Restart

When you modify parameters, you must restart the router for the change to take effect. Enter the following three commands in the order shown:

At the prompt		Enter the Command
<code>TKR Config></code>	(TKR Config prompt)	exit
<code>Config></code>	(CONFIG prompt)	control/p
*	(System prompt)	restart

If you need to configure additional software, refer to the *Distributed Routing System Software Guide*.

Configuring Ethernet Port 2 Connection

This section describes how to configure the Ethernet port 2 configuration for front connections (connector on the front of the module only). This does not apply when port 2 is configured to run on the DEChub 900 backplane.

Step	Action
1	At the Config> prompt enter: net 2 Example: Config> net 2
2	At the ETH config> prompt enter either: connect AUI connect RJ45 (10BaseT) Auto-Config Example: ETH config> connect AUI

To Exit and Restart

When you modify parameters, you must restart the module for the change to take effect. Enter the following three commands in the order shown:

At the prompt	Enter the Command
ETH Config> (ETH Config prompt)	exit
Config> (CONFIG prompt)	control/p
*	(System prompt) restart

If you need to configure additional software, refer to the *Distributed Routing System Software Guide*.

Configuring OBM

This section describes how to set the OBM IP address and speed. After entering **talk 6**, at the `Config>` prompt you can set the following OBM parameters as follows:

Parameter	Description	Default
set obm ip-address Example: set obm 16.40.156.20	Sets the out-of-band management port IP-address (for example, 16.40.156.20).	current IP-address
set obm speed Example: set obm 38400	Sets the OBM port speed (2400, 9600, or 38400 bps).	9600
set obm RTS Example: set obm rts	Enables or disables RTS.	disabled

To Exit and Restart

When you modify parameters, you must restart the router for the change to take effect. Enter the following commands

At the prompt	Enter the Command
<code>Config></code>	(CONFIG prompt) control/p
*	(System prompt) restart

If you need to configure additional software, refer to the *Distributed Routing System Software Guide*.

Chapter 6

Removing the Module

Overview

Introduction

This chapter describes how to remove the DECswitch 900ET from a DEChub 900 MultiSwitch. If you need instructions on how to remove the DECswitch 900ET from a standalone module, refer to the *DEChub ONE Installation* manual.

In this chapter

Topic	Page
Removing the Cables	6-2
Unseating the Module	6-3

Removing the Cables

To remove cables from the module, complete the steps in the following table that is appropriate for your type of cable (see Figure 6-1).

Step	Action
1	Remove 9-pin Token Ring cables, use a flat-headed screwdriver to loosen the two screws, then pull out the cable.
2	Remove UTP/STP cables, press the release tab on the cable plug, then pull out the cable.
3	Remove AUI cables, push the connector slide latch up to the unlocked position, then pull out the cable.

Figure 6-1: Cable Removal

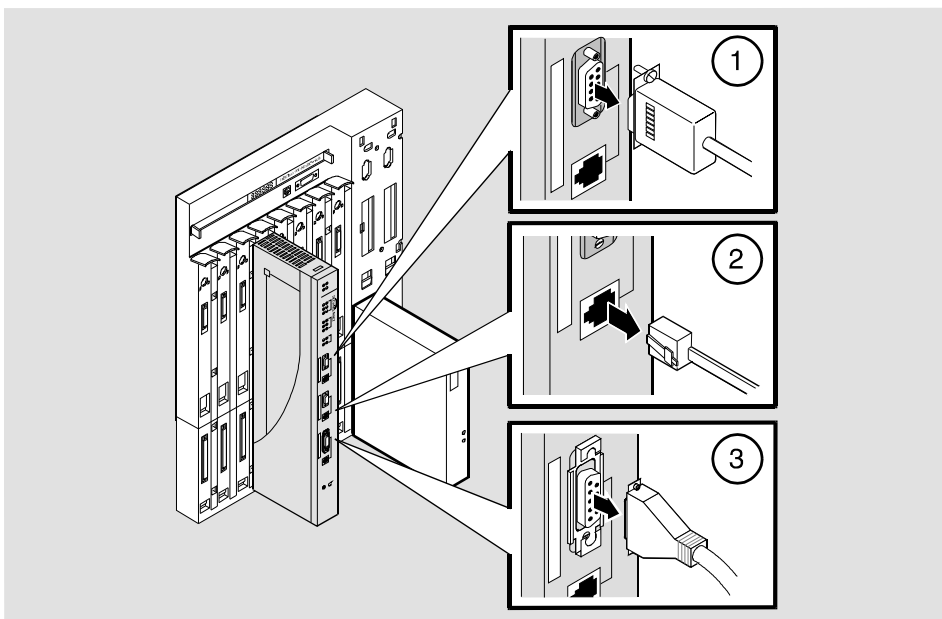

NPG-0323-95F

Unseating the Module

To unseat the module from the DEChub 900, complete the following steps (see Figure 6-2).

Step	Action
1	Lift the release lever (1) located at the top of the DEChub 900 slot.
2	While holding up the release lever (2), pivot the module back on its bottom mounting tab (3).
3	Remove the module.

Figure 6-2: Unseat the Module

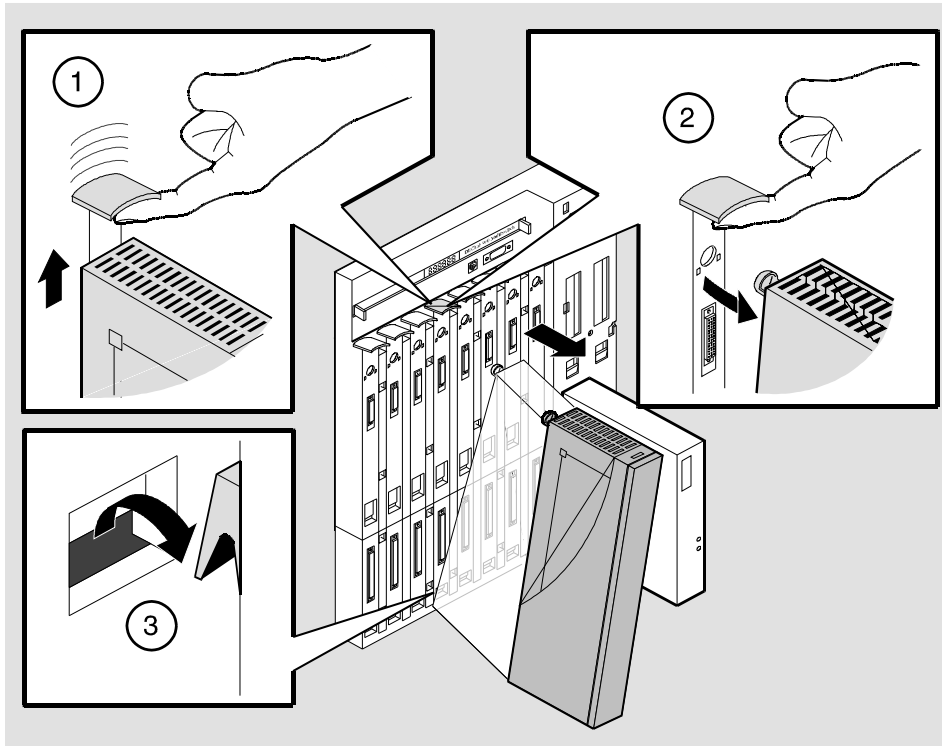

NPG-0008-95F

Appendix A

Problem Solving

Overview

Introduction

This appendix describes how to diagnose and solve problems with the module using the LED displays.

In this chapter

Topic	Page
LED Descriptions	A-2
Problem Solving Using LEDs	A-3

LED Descriptions

The module's LEDs provide dynamic indications of the status of the module. The LEDs can be in various states (on, off, or flashing) depending on the operational status of the module or the level of activity on the network.



Normal Powerup

When the module's power is initially turned on, the following events occur:

Event	Description
1	The module's Power LED lights as soon as power is applied to the unit.
2	The module initiates its built-in self-test. LEDs indicate that the module is running various subroutines as part of the self-test.
3	After the successful completion of self-test (within 60 seconds after power is applied), the Module OK LED lights, and remains lit.

Table A-1 shows the states that are possible for two of the module's LEDs. Table 1-1 in Chapter 1 shows and describes all LEDs and their operational status, after configuration.

Table A-1: LED States

LED Name	Off	On (Green)	Flashing
Power 	No power to module.	Module receiving power	N/A
Module OK 	Self-test failed (if more than 60 seconds elapsed).	Passed self-test.	Non-fatal failure. Example: Fan Failure

Problem Solving Using LEDs

When diagnosing a problem with the module, note that the problem is often indicated by the combined states of the module's LEDs. Table A-2 lists the typical combined states of the LEDs for various error conditions that can occur during initial installation of the device, along with probable causes and corrective actions to take.

Table A-2: Solving Problems Using LEDs

Symptom	Probable Cause	Corrective Action
Power LED is off.	The module is not receiving +5Vdc.	<p>Check the power status on the Hub Manager status display.</p> <p>If the Hub Manager status display indicates that power is available for this module, press the release lever and reseat or remove the module.</p> <p>Inspect the module's 48- or 160-pin connectors for bent, or broken pins. If pins are bent or broken replace the module.</p> <p>If the problem persists, either replace the module or contact your service representative to correct the problem.</p>

(continued)

Problem Solving Using LEDs

Table A-2 (Cont.): Solving Problems Using LEDs

Symptom	Probable Cause	Corrective Action
Module OK LED is off.	Self-test in progress.	Wait for self-test to complete.
	Self-test failed.	If the LED does not light within 60 seconds, lift the release lever momentarily to repeat the self-test. If self-test fails again, replace the module. If the problem persists, contact your service representative to correct the problem.
Module OK LED is flashing, but module continues to operate normally.	A nonfatal error occurred.	Turn power off and on. If the problem persists, either replace the module or contact your service representative to correct the problem.

Appendix B

Connector and Pin Assignments

Overview

Introduction

This appendix shows the pin assignments of the connectors, cables, and adapters that are part of, or can be used with, the module.

In this chapter

Topic	Page
Connector Assignments	B-2
Internal and External Crossover Configurations	B-6

Connector Assignments

Token Ring (9-pin) Port Connector

This section shows the 9-pin D-SUB connector for 150-ohm STP cables and its pin assignments.

Table B-1: Token Ring (9-pin) Pin Assignments

Pin No.	Assignment
1	RX+ (Ring Receive)
2	NC (No Connect)
3	NC (No Connect)
4	NC (No Connect)
5	TX+ (Ring Transmit)
6	RX- (Ring Receive)
7	NC (No Connect)
8	NC (No Connect)
9	TX- (Ring Transmit)

Figure B-1: Token Ring (9-pin) Connector

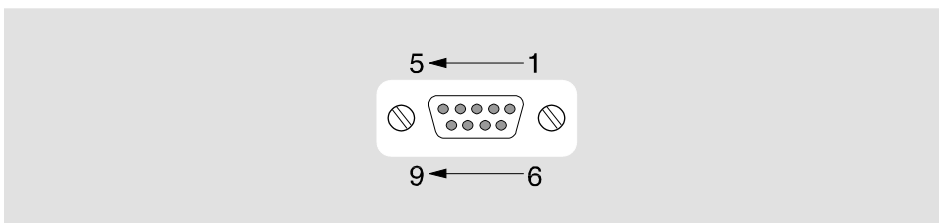

NPG-0299-95F

Token Ring (8-pin MJ) Port Connector

This section shows the 8-pin MJ connector for UTP type cables and its pin assignments.

Table B-2: Token Ring UTP 8-pin MJ Pin Assignments

Pin No.	Assignment
1	NC (No Connect)
2	NC (No Connect)
3	TX+ (Ring Transmit)
4	RX+ (Ring Receive)
5	RX- (Ring Receive)
6	TX- (Ring Transmit)
7	NC (No Connect)
8	NC (No Connect)

Figure B-2: Token Ring 8-pin MJ Connector

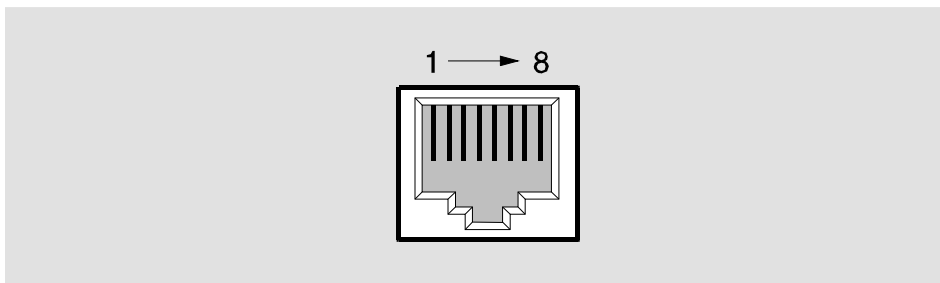

NPG-8719-95F

Connector Assignments

AUI (15-pin) Port Connector

This section shows the 15-pin Sub-D AUI connector and its pin assignments.

Table B-3: AUI 15-Pin Port Connector Pin Assignments

Pin No.	Assignment
1	CI- Shield
2	CI-A
3	DO-A
4	DI-Shield
5	DI-A
6	V-Common
7	NC (No Connect)
8	NC (No Connect)
9	CI-B
10	DO-B
11	DO-Shield
12	DI-B
13	V-Plus
14	V-Shield
15	NC (No Connect)

Figure B-3: AUI 15-Pin Port Connector

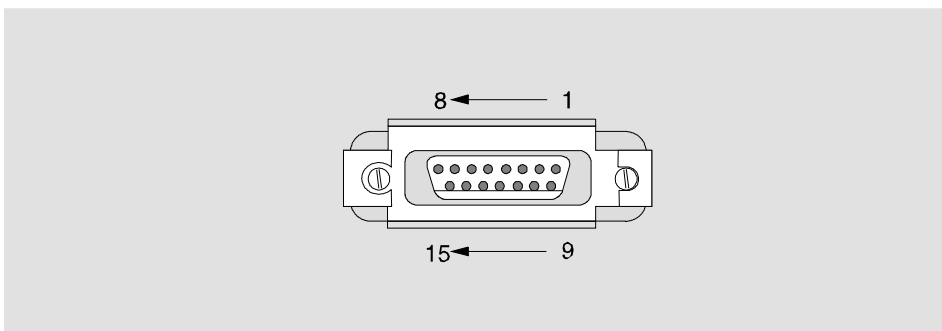

NPG-0222-95F

10BaseT (8-pin MJ) Port Connector

This section shows the 8-pin MJ Twisted Pair connector and its pin assignments.

Table B-4: Ethernet 8-pin MJ Connector Pin Assignments.

Pin No.	Assignment
1	TX+ (Ring Transmit)
2	TX- (Ring Transmit)
3	RX+ (Ring Receive)
4	NC (No Connect)
5	NC (No Connect)
6	RX- (Ring Receive)
7	NC (No Connect)
8	NC (No Connect)

Figure B-4: Ethernet 8-pin MJ Connector

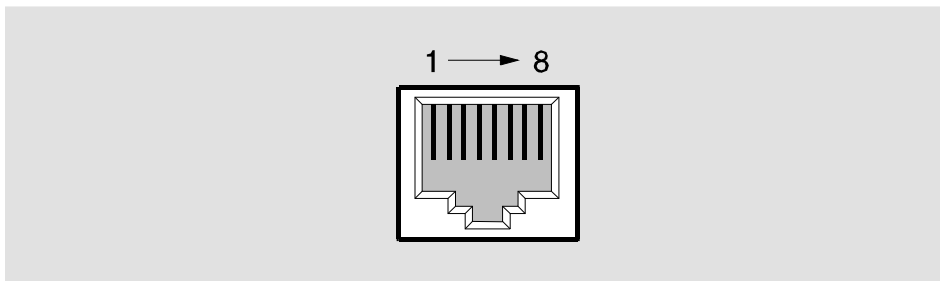

NPG-8719-95F

Internal and External Crossover Configurations

A crossover function must be implemented in every twisted-pair link. The crossover function (internal or external) allows the transmitter of one device to connect to the receiver of the device at the other end of the twisted-pair link.

Figure B-5 shows straight-through (1) and crossover cables (2) for connecting crossover crossover (3) and straight-through (4) types of devices. The DECswitch 900ET Router uses straight-through connectors.

Figure B-5: Crossover Configurations

External Crossover Configuration:

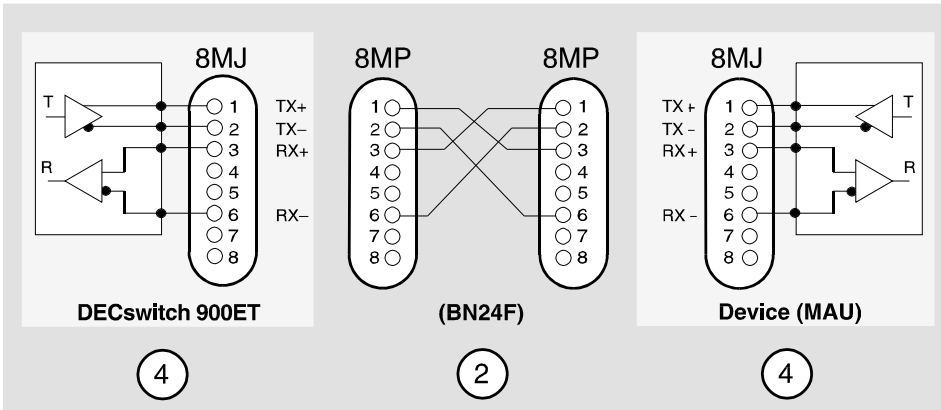

Internal Crossover Configuration:

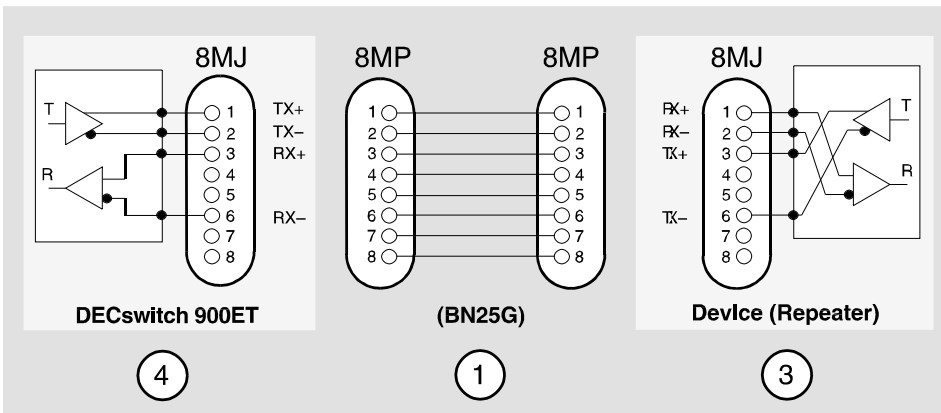

NPG-0298-95F

¹ If screened cabling is required, use BN26M.

Appendix C

Product Specifications

Overview

Introduction

This appendix lists the operating specifications and the acoustical specifications for the DECswitch 900ET.

In this chapter

Topic	Page
Operating Specifications	C-2
Acoustical Specifications	C-5

Operating Specifications

This section shows the operating specifications.

Table C-1: Operating Environment

Parameter	Specification
Operating Temperature ¹	5° C to 50° C (41° F to 122° F)
Relative Humidity	10% to 95% noncondensing
Altitude:	
Operating Altitude	Sea level to 2400 Meters (8,000 feet)
Non Operating Altitude	Sea level to 4900 Meters (16,000 feet)
Power	29 W, total power: 3.4 A, 5Vdc 0.1 A, 12Vdc ² 0.72 A, 15Vdc

Table C-2: Connector Specifications

Module Connectors

DECswitch 900ET has: two 9-pin Token Ring ports for the 150-ohm STP, one 15-pin D-Sub (AUI ports), two 8-pin MJ8 UTP Token Ring ports, and one shielded 8-pin MJ (10BaseT ports) with straight through connectors.

DEChub ONE has: one 8-pin MJ (setup port), one DB-9 (OBM), and one 15-pin D-Sub (AUI connector).

Legend

¹For sites above 4900 m (16,000 ft), decrease the operating temperature specification by 1.8 C for each 1000 m or 3.2 F for each 3200 ft.

²The 12Vdc power in the DEChub 900 is derived from the 15Vdc power source. Although it is listed separately in the product specifications, the 12Vdc requirements are included in the 15Vdc power total.

Operating Specifications

Table C-3: Physical Specifications in a DEChub ONE

Parameter	Specification
Height	4.45 cm (1.75 in)
Depth	15.25 cm (6.0 in); 25.40 cm (10.0 in) with a DEChub ONE.
Width	44.5 cm (17.5 in)
Weight	Module 3.05 lbs ¹ Module in Box (no documentation) = 4.60 lbs. Module with DEChub ONE = 6.45 lbs.
Shipping Carton Dimensions	50.5 x 29.3 x 10.7cm (20 x 11.625 x 4.25 in)

Legend

¹Current values for specific configurations are available from Digital Equipment representatives.
1 B = 10 dBA.

Operating Specifications

Table C-4: Physical Specifications in a DEChub 900

Parameter	Specification
Height	44.5 cm (17.5 in)
Depth	15.25 cm (6.0 in)
Width	4.45 cm (1.75 in)
Weight	Module 3.05 lbs ¹ Module in Box (no documentation) = 4.60 lbs.
Shipping Carton Dimensions	50.5 x 29.3 x 10.7cm (20 x 11.625 x 4.25 in)

Legend

¹Current values for specific configurations are available from Digital Equipment representatives.
1 B = 10 dBA.

Table C-5: Certification

Certification
CE, CSA, FCC, TUV, UL, VCCI

Acoustical Specifications

This section shows the acoustical specifications.

Acoustics - Declared values per ISO 9296 and ISO 7779¹

Table C-6: Acoustical Specifications

Product	Sound Power Level LWAd, B	Sound Pressure Level LpAm, dBA (bystander positions)
	<u>Idle/Operate:</u>	<u>Idle/Operate:</u>
DECswitch 900ET DETER-MA	4.9	35
DECswitch 900ET & DEChub ONE DETER-MA + DEHUA	5.3	39

Legend

¹Current values for specific configurations are available from Digital Equipment representatives.
1 B = 10 dBA.

Acoustical Specifications

Schallemissionswerte - Werteangaben nach ISO 9296 und ISO 7779/DIN EN27779²

Table C-7: Aktuelle Werte für spezielle Produkt

Produkt	Schalleistungspiegel LWAd, B	Schalldruckpegel LpAm, dBA (Zuschauerpositionen)
	<u>Leerlauf/Betrieb:</u>	<u>Leerlauf/Betrieb:</u>
DECswitch 900ET DETER-MA	4,9	35
DECswitch 900ET & DEChub ONE DETER-MA + DEHUA	5,3	39

Legend

²Aktuelle Werte für spezielle Ausrüstungsstufen sind über die Digital Equipment Vertretungen erhältlich. 1 B = 10 dBA.